

# Air Tube Disc Clutches and Brakes

## Spring-Set Air Release Brakes

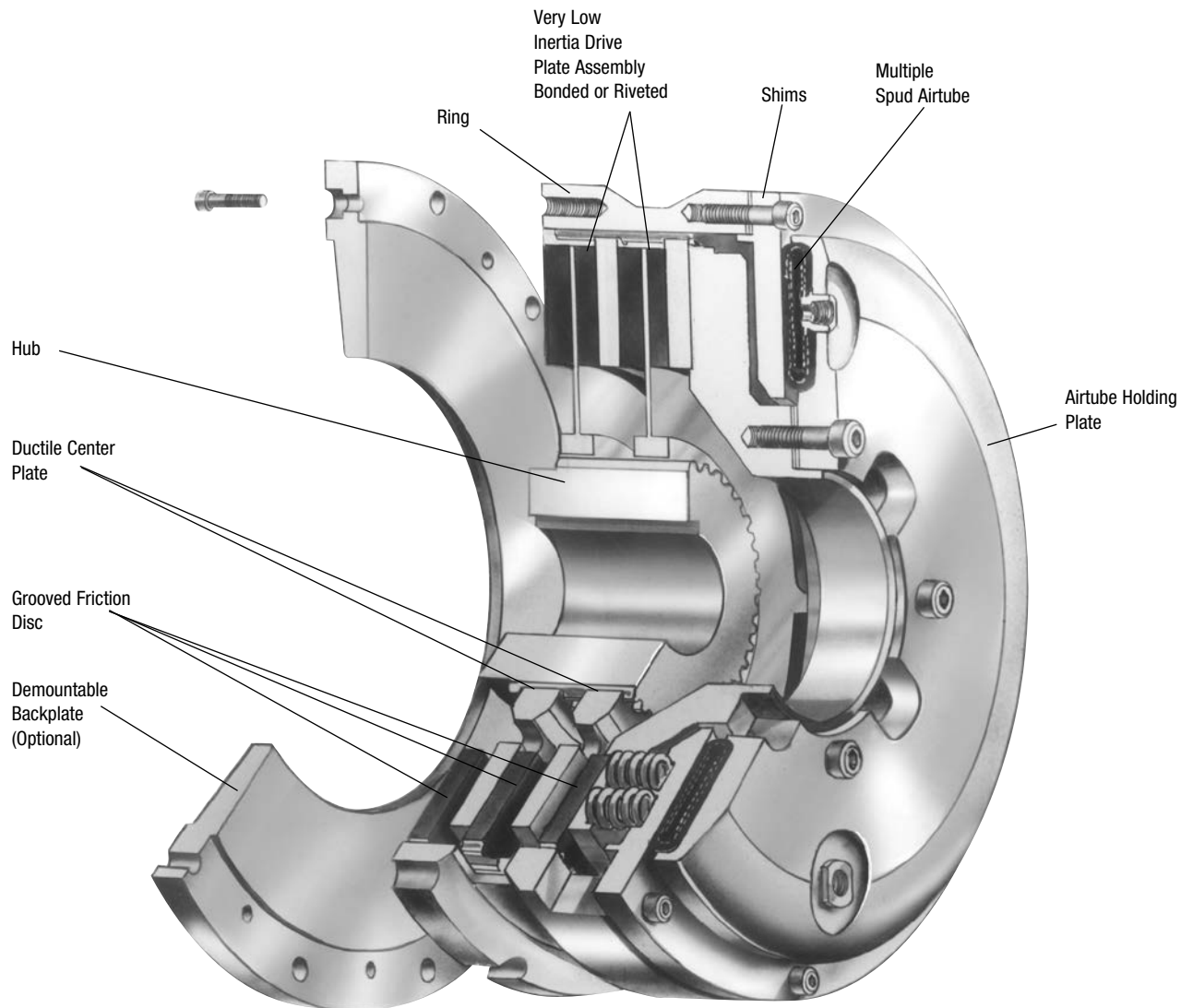

Wichita Spring-Set Air Release Brakes are ideal for fail safe protection of process equipment. Constructed of high strength cast iron, this improved design has thick friction discs for longer wear life. The fast acting air-tube design assures quick, smooth stops.

- No lubrication
- No adjustment
- Available in vertical mount
- Quick, simple installation
- Explosion proof design

### Selection requirements

The selection of a Low Inertia Brake is based on:

1. Torque required to stop a load
2. Friction area necessary to absorb rotational energy
3. Contact velocity of rotating discs
4. Maximum bore capacity of unit

# Air Tube Disc Clutches and Brakes

## Spring-Set Air Release Brakes

### Selection

### Low Inertia Spring-Set Brake

To properly select a brake, the total rotating inertia,  $WR^2$ , must be reflected to the brakeshaft.

#### Application Data:

Refer to page 45, except, cyclic operation—7 CPM, and 218 Very Low Inertia Clutch.

Alternate Shaft  $WR^2$  referred to clutch shaft =

$$(\text{Alternate Shaft } WR^2) \left( \frac{\text{Alternate Shaft RPM}}{\text{Clutch Brake Shaft RPM}} \right)^2$$

$WR^2$  referred to clutch-brake shaft

$$= (39,091) \left( \frac{30}{204} \right)^2$$

$WR^2$  referred to clutch-brake shaft  
= 845.4 lb.ft.<sup>2</sup> @ 204 RPM

Crank Shaft  $WR^2$  = 845.4 lb.ft.<sup>2</sup>

Clutch-Brake Shaft  $WR^2$  = 78.2 lb.ft.<sup>2</sup>

Clutch Hub and Drive Plate  $WR^2$   
from Specification Table = 14.7 lb.ft.<sup>2</sup>  
(page 61)

Est. Brake  $WR^2$  = 14.7 lb.ft.<sup>2</sup>

Est. Total  $WR^2$  = 953.0 lb.ft.<sup>2</sup>

#### Brake Selection:

Stopping angle of crank shaft =  $120^\circ = \varnothing_b$   
Use  $90^\circ$  for calculation

#### Estimated time to stop:

$$t = \left( \frac{\varnothing_b}{360^\circ} \right) \left( \frac{60}{\text{crank shaft RPM}} \right)$$

$$= \left( \frac{90}{360} \right) \left( \frac{60}{30} \right) = .5 \text{ sec.}$$

Deceleration Torque

$$= (12) \left( \frac{WR^2}{32.2} \right) \left( \frac{\text{clutch-brake RPM}}{(9.5) (t)} \right)$$

$$= (12) \left( \frac{953}{32.2} \right) \left( \frac{204}{(9.5) (.5)} \right)$$

= 15,250 lb.in.

HP/100 RPM

$$= \frac{15,250}{630} = 24 \text{ HP/100 RPM}$$

#### From duty chart (page 23) “Group B” for spring-set brake (SS):

214 SS Brake is rated @ 28 HP/100 RPM  
90% torque rating = 24,800 lb.in.

$WR^2$  of 214 SS VLI Brake = 4.5 lb.ft.<sup>2</sup>, therefore  
deceleration torque calculation is correct.

\*Average heat horsepower to clutch & brake.

$$\text{Avg. heat HP} = \frac{(\text{Total } WR^2) (\text{RPM}^2) (\text{CPM})}{1.9 \times 10^8}$$

$$= \frac{(953) (41,616) (7)}{1.9 \times 10^8} = 1.45 \text{ HP}$$

\*Check with factory for heat capacity.

#### Note:

This application example is for preliminary sizing only. Contact a Wichita Sales Engineer or the factory for final selection.

# Air Tube Disc Clutches and Brakes

## Spring-Set Brakes

### Specifications

Model Size ATD-	Assembly Number 60 PSI Release	Slip Torque Capacity						Max. Bore Rect. Key	
		60 PSI	lb.in. 75 PSI	90 PSI	4.1 BAR	Nm 5.2 BAR	6.2 BAR	in.	(mm)
SSB 104H	71104-730*	451				51			1.00 (25)
SSB 106	7-106-100-200-0	2,225	2,900	3,700	251	328	418		
SSB 206	7-106-200-200-0	4,300	5,600	7,200	486	633	813	2.00	(50)
SSB 306	7-106-300-100-0*	5,750	7,400	9,050	650	836	1,022		
SSB 108	7-108-100-123-0	3,700	4,800	6,200	418	542	700		
SSB 208	7-108-200-121-0	7,100	9,100	12,000	802	1,028	1,356	2.25	(57)
SSB 308	7-108-300-101-0	8,800	11,300	13,400	994	1,277	1,514		
SSB 111	7-111-100-102-0	8,200	10,500	11,600	926	1,186	1,311		
SSB 211	7-111-200-100-0	15,600	20,000	22,200	1,763	2,260	2,508	2.50	(64)
SSB 311	7-111-300-100-0	19,300	24,900	28,400	2,181	2,813	3,209		
SSB 114	7-114-100-127-0	14,500	18,600	24,700	1,638	2,101	2,791		
SSB 214	7-114-200-103-0	27,600	35,400	46,300	3,118	4,000	5,231	3.50	(89)
SSB 314	7-114-300-100-0	36,000	44,700	53,900	4,067	5,050	6,090		
SSB 116	7-116-100-100-0	19,300	23,800	28,400	2,181	2,689	3,209		
SSB 216	7-116-200-100-0	35,300	44,700	53,400	3,988	5,050	6,033	4.00	(102)
SSB 316	7-116-300-100-0	49,500	62,600	75,000	5,593	7,073	8,474		
SSB 118	7-118-100-100-0	31,400	40,400	51,600	3,548	4,564	5,830		
SSB 218	7-118-200-100-0	60,000	77,000	100,000	6,779	8,700	11,298	4.75	(120)
SSB 318	7-118-300-100-0	80,900	102,000	122,000	9,140	11,524	13,784		
SSB 121	7-121-100-100-0	38,300	47,400	57,400	4,327	5,355	6,485		
SSB 221	7-121-200-100-0	71,700	88,800	107,600	8,101	10,033	12,157	6.00	(152)
SSB 321	7-121-300-101-0	100,200	124,100	150,400	11,321	14,021	16,992		
SSB 124H	7-125-100-100-0	75,500	86,600	—	8,530	9,784	—		
SSB 224H	7-125-200-100-0	137,000	161,200	—	15,478	18,213	—	6.00	(152)
SSB 324H	7-125-300-100-0	178,900	223,600	—	20,212	25,263	—		
SSB 127	7-127-100-105-0	75,300	94,200	113,400	8,508	10,643	12,812		
SSB 227	7-127-200-118-0	140,900	176,200	212,100	15,919	19,907	23,963	6.50	(165)
SSB 327	7-127-300-102-0	196,700	245,900	296,000	22,223	27,782	33,443		
SSB 130H	7-131-100-101-0	162,200	211,700	260,500	18,326	23,918	29,432		
SSB 230H	7-131-200-100-0	310,000	404,500	495,500	35,024	45,701	55,982	7.25	(184)
SSB 330H	7-131-300-305-0	395,500	496,100	589,900	44,684	56,050	66,648		
SSB 136H	7-137-100-100-0	254,500	300,000	400,000	28,754	33,894	45,193	9.00	(229)
SSB 236H	7-137-200-104-0	477,500	564,000	760,000	53,949	63,722	85,866	10.00	(254)
SSB 336H	7-137-300-101-0*	675,000	840,100	1,012,600	76,263	94,916	114,405	10.00	(254)
SSB 436H	7-137-400-102-0	868,800	1,081,300	1,303,400	98,158	122,167	147,260	10.00	(254)
SSB 142	7-142-100-302-0	425,000			48,017				
SSB 242	7-142-200-306-0	796,000			89,933			14.00	(355)
SSB 342	7-142-300-301-0	1,072,000			121,116				
SSB 148	7-148-100-300-0	698,250			78,889				
SSB 248	7-148-200-300-0	1,335,000			150,830			18.00	(455)
SSB 348	7-148-300-103-0	1,726,000			195,006				
SSB 260	7-160-200-300-0	3,255,000			367,755				
SSB 360	TBD	4,921,000			555,982			19.00	(480)
SSB 460	TBD	5,355,000			605,016				

\* Not the standard 60 PSI release pressure. See following pages for release pressure per assembly.

# Air Tube Disc Clutches and Brakes

## Spring-Set Brakes Specifications

Model Size ATD-	Recom- mended Clearance in.	Balance Speed RPM	Hub & C.P.		Swept Area in. <sup>2</sup>	Airtube Volume in. <sup>3</sup> (cm <sup>3</sup> )		Total Brake Wt.		Hub & Center Plate Wt. WR <sup>2</sup> /J=mr <sup>2</sup>			
			Reg- Speed RPM	High Speed RPM*		New	Worn	lb.	(kg)	lb.	(kg)	WR <sup>2</sup> /J=mr <sup>2</sup>	
												lb.ft. <sup>2</sup>	kgm <sup>2</sup>
SSB 104H	1/32-1/16	3,325	5,250	5,250*	17	0.9	3.4	11.0	(7)	1.54	(0.7)	0.021	(0.001)
SSB 106	1/16-3/32				39								
SSB 206	3/32-1/8	2,225	3,800	5,700*	78	1.8	11.9	27.5	(12)	6.40	(2.9)	0.24	(0.010)
SSB 306	3/32-1/8				117			40.5	(18)	12.17	(5.5)	0.46	(0.019)
SSB 108	1/16-1/8				56			62	(28)	11	(5.0)	0.54	(0.023)
SSB 208	3/32-5/32	1,675	2,870	4,300*	112	3.4	18.3	70	(32)	19	(8.6)	1.00	(0.042)
SSB 308	1/8-3/16				168	(56)	(300)	87	(39)	28	(12.7)	2.00	(0.084)
SSB 111	1/16-1/8				114			130	(59)	23	(10.4)	2.30	(0.097)
SSB 211	3/32-5/32	1,200	2,090	3,125*	228	5.5	30.5	166	(75)	45	(20.4)	4.50	(0.190)
SSB 311	1/8-3/16				342			208	(94)	121	(54.9)	7.00	(0.295)
SSB 114	1/16-1/8				158			184	(83)	46	(20.9)	5.7	(0.240)
SSB 214	3/32-5/32	950	1,640	2,450*	316	7.6	42.7	233	(106)	77	(34.9)	11.0	(0.464)
SSB 314	1/8-3/16				474	(125)	(700)	290	(132)	121	(54.9)	16.7	(0.704)
SSB 116	1/16-1/8				228			254	(115)	59	(26.8)	10.2	(0.430)
SSB 216	3/32-5/32	835	1,430	2,150*	455	9.8	56.1	326	(148)	106	(48.1)	19.6	(0.826)
SSB 316	1/8-3/16				683	(161)	(919)	358	(162)	151	(68.5)	29.6	(1.248)
SSB 118	1/16-1/8				264			311	(141)	73	(33.1)	15.0	(0.632)
SSB 218	3/32-5/32	750	1,270	1,910*	528	15.3	85.4	377	(171)	120	(54.4)	28.8	(1.214)
SSB 318	1/8-3/16				792	(251)	(1,400)	461	(209)	180	(81.6)	43.2	(1.821)
SSB 121	3/32-5/32				362			460	(209)	116	(52.6)	32	(1.35)
SSB 221	1/8-3/16	650	1,090	1,650*	724	18.3	97.6	575	(261)	198	(89.8)	61	(2.57)
SSB 321	5/32-7/32				1,086	(300)	(1,599)	723	(328)	312	(141.5)	122	(5.14)
SSB 124H	3/32-5/32				574			618	(280)	132	(60.0)	56	(2.4)
SSB 224H	1/8-3/16	550	950	1,410*	1,148	29.9	159	840	(381)	260	(117.9)	110	(4.6)
SSB 324H	5/32-7/32				1,722	(490)	(2,606)	1,025	(465)	379	(172.0)	160	(6.8)
SSB 127	3/32-5/32				730			760	(345)	187	(84.8)	98	(4.1)
SSB 227	1/8-3/16	500	850	1,250*	1,460	29.9	159	924	(419)	329	(149.2)	191	(8.1)
SSB 327	5/32-7/32				2,190	(490)	(2,606)	1,112	(504)	555	(251.7)	285	(12.0)
SSB 130H	3/32-5/32				827			972	(441)	298	(135.2)	189	(8.0)
SSB 230H	1/8-3/16	450	765	1,130*	1,654	58.6	311	1,350	(612)	546	(247.7)	370	(15.6)
SSB 330H	5/32-7/32				2,481	(960)	(5,096)	1,751	(794)	810	(367.4)	477	(20.1)
SSB 136H	3/32-5/32				1,150			1,388	(630)	461	(209.1)	372	(15.7)
SSB 236H	1/8-3/16	375	640	950*	2,300	110	415	1,993	(904)	708	(321.1)	725	(30.6)
SSB 336H	5/32-7/32				3,450	(1,803)	(6,801)	2,610	(1,184)	1,134	(514.4)	1,091	(46.0)
SSB 436H	3/16-1/4				4,600			4,025	(1,826)	1,600	(697)	1,457	(61.4)
SSB 142	5/32-7/32				1,400			1,967	(892)	680	(308)	705	(30)
SSB 242	3/16-1/4	325	545	805*	2,800	128	488	2,732	(1,239)	1,197	(543)	1,385	(58)
SSB 342	7/32-9/32				4,200	(2,098)	(7,997)	3,704	(1,680)	1,324	(601)	1,809	(76)
SSB 148	1/8-1/4				2,010			3,158	(1,432)	1,101	(499)	1,785	(75)
SSB 248	7/32-9/32	275	475	705*	4,020	217	824	4,700	(2,132)	1,942	(881)	3,335	(141)
SSB 348	3/16-5/16				6,030	(3,550)	(13,500)	6,540	(2,966)	2,950	(1,338)	4,925	(208)
SSB 260	3/16-5/16				7,230			9,453	(4,288)	2,567	(1,164)	7,077	(298)
SSB 360	1/4-3/8	225	380	575*	10,845	513	1,788	11,643	(5,281)	3,870	(1,755)	10,615	(448)
SSB 460	5/16-7/16				14,460	(8,407)	(29,300)	14,500	(6,577)	5,700	(2,585)	15,070	(635)

\* Consult Factory for Special Assembly Number.

# Air Tube Disc Clutches and Brakes

## Specifications

Model Size ATD-	Release Pressure PSI	BAR	Assembly Number	Duty Factors HP/100 RPM			
				A	B	C	D
SSB 104H	65	4.5	71104-730	0.7	0.5	0.3	0.1
	60	4.1	7-106-100-200-0	3	2.3	1.2	0.6
SSB 106	75	5.2	7-106-100-216-0	4	3	1.5	0.8
	90	6.2	7-106-100-217-0	5	3.8	2	1
SSB 206	60	4.1	7-106-200-200-0	6	4.4	2.3	1.1
	75	5.2	7-106-200-205-0	8	5.7	3	1.5
	90	6.2	7-106-200-206-0	10	7.4	3.9	2
SSB 306	80	5.5	7-106-300-100-0	11.7	8.2	4.1	2.1
	60	4.1	7-108-100-123-0	5.3	3.8	2	1
SSB 108	75	5.2	7-108-100-124-0	7	5	2.6	1.3
	90	6.2	7-108-100-125-0	9	6.3	3.3	1.6
	60	4.1	7-108-200-121-0	10	7.3	3.8	2
SSB 208	75	5.2	7-108-200-122-0	13	9.3	5	2.5
	90	6.2	7-108-200-110-0	17	12.3	6.5	3.2
	60	4.1	7-108-300-101-0	14	9.8	4.9	2.4
SSB 308	75	5.2	7-108-300-102-0	17.9	12.6	6.3	3.1
	90	6.2	7-108-300-103-0	21.3	14.9	7.4	3.7
	60	4.1	7-111-100-102-0	11.7	8.4	4.4	2.2
SSB 111	75	5.2	7-111-100-120-0	15	10.7	5.7	2.8
	90	6.2	7-111-100-121-0	16.6	12	6.3	3.1
	60	4.1	7-111-200-100-0	22	16	8.4	4.2
SSB 211	75	5.2	7-111-200-126-0	28.6	20.5	11.0	5.4
	90	6.2	7-111-200-127-0	35.2	24.7	12.3	6.2
	60	4.1	7-111-300-100-0	30.6	21.4	10.7	5.4
SSB 311	75	5.2	7-111-300-103-0	39.5	27.7	13.8	6.9
	90	6.2	7-111-300-104-0	45.1	31.6	15.8	7.9
	60	4.1	7-114-100-127-0	20	15	6	4
SSB 114	75	5.2	7-114-100-101-0	26.6	19	10	5
	90	6.2	7-114-100-128-0	35	25	13	6.7
	60	4.1	7-114-200-103-0	39	28	15	7.5
SSB 214	75	5.2	7-114-200-108-0	50	36	19	9.5
	90	6.2	7-114-200-122-0	66	47	25	12.5
	60	4.1	7-114-300-100-0	57.1	40	20	10
SSB 314	75	5.2	7-114-300-104-0	71	49.7	24.8	12.4
	90	6.2	7-114-300-105-0	85.6	59.9	29.9	15
	60	4.1	7-116-100-100-0	31	21	11	5
SSB 116	75	5.2	7-116-100-110-0	38	26	13	7
	90	6.2	7-116-100-111-0	45	32	16	8
	60	4.1	7-116-200-100-0	56	39	20	10
SSB 216	75	5.2	7-116-200-116-0	71	50	25	12
	90	6.2	7-116-200-117-0	85	59	30	15
	60	4.1	7-116-300-100-0	79	55	28	14
SSB 316	75	5.2	7-116-300-101-0	99	50	25	12
	90	6.2	7-116-300-102-0	119	83	42	21
	60	4.1	7-118-100-100-0	45	32	17	8.5
SSB 118	75	5.2	7-118-100-136-0	58	41	22	11
	90	6.2	7-118-100-137-0	74	53	28	14
	60	4.1	7-118-200-100-0	86	61	32	16
SSB 218	75	5.2	7-118-200-148-0	110	79	41	21
	90	6.2	7-118-200-149-0	143	102	54	27
	60	4.1	7-118-300-100-0	128	90	45	22
SSB 318	75	5.2	7-118-300-104-0	162	113	57	28
	90	6.2	7-118-300-105-0	194	136	68	34

# Air Tube Disc Clutches and Brakes

## Specifications

Model Size ATD-	Release Pressure		Assembly Number	Duty Factors HP/100 RPM			
	PSI	BAR		A	B	C	D
SSB 121	60	4.1	7-121-100-100-0	61	43	21	11
	75	5.2	7-121-100-106-0	75	53	26	13
	90	6.2	7-121-100-107-0	91	64	32	16
SSB 221	60	4.1	7-121-200-100-0	114	80	40	20
	75	5.2	7-121-200-118-0	141	99	49	25
	90	6.2	7-121-200-119-0	171	120	60	30
SSB 321	60	4.1	7-121-300-101-0	159	111	56	28
	75	5.2	7-121-300-102-0	197	138	69	34
	90	6.2	7-121-300-103-0	239	167	84	42
SSB 124H	60	4.1	7-125-100-100-0	108	77	41	20
	75	5.2	7-125-100-124-0	137	96	48	24
SSB 224H	60	4.1	7-125-200-100-0	196	140	74	37
	75	5.2	7-125-200-134-0	256	179	90	45
SSB 324H	60	4.1	7-125-300-100-0	284	199	99	50
	75	5.2	7-125-300-104-0	355	248	124	62
SSB 127	60	4.1	7-127-100-105-0	120	84	42	21
	75	5.2	7-127-100-100-0	150	105	53	26
	90	6.2	7-127-100-106-0	180	126	63	32
SSB 227	60	4.1	7-127-200-118-0	224	157	78	39
	75	5.2	7-127-200-100-0	280	196	98	49
	90	6.2	7-127-200-119-0	337	236	118	59
SSB 327	60	4.1	7-127-300-102-0	312	219	109	55
	75	5.2	7-127-300-100-0	390	273	137	68
	90	6.2	7-127-300-103-0	470	329	164	82
SSB 130H	60	4.1	7-131-100-101-0	232	166	88	44
	75	5.2	7-131-100-104-0	303	217	115	57
	90	6.2	7-131-100-105-0	372	267	141	70
SSB 230H	60	4.1	7-131-200-100-0	443	318	167	84
	75	5.2	7-131-200-110-0	578	415	218	110
	90	6.2	7-131-200-111-0	710	508	268	134
SSB 330H	60	4.1	7-131-300-305-0	628	439	220	110
	75	5.2	7-131-300-306-0	787	551	276	138
	90	6.2	7-131-300-307-0	936	655	328	164
SSB 136H	60	4.1	7-137-100-100-0	404	283	141	71
	75	5.2	7-137-100-101-0	476	333	167	83
	90	6.2	7-137-100-102-0	635	444	222	211
SSB 236H	60	4.1	7-137-200-104-0	758	531	265	133
	75	5.2	7-137-200-105-0	895	627	313	157
	90	6.2	7-137-200-106-0	1,206	844	422	211
SSB 336H	60	4.1	7-137-300-101-0	917	642	321	160
	75	5.2	7-137-300-102-0	1,155	808	404	202
	90	6.2	7-137-300-103-0	1,381	967	483	242
SBB 436H	60	4.1	7-137-400-102-0	1,616	1,132	564	284
	75	5.2	7-137-400-103-0	1,904	1,332	668	332
	90	6.2	7-137-400-104-0	2,540	1,776	888	444
SSB 142	60	4.1	7-142-100-302-0	610	435	230	115
SSB 242	60	4.1	7-142-200-306-0	1,140	815	430	215
SSB 342	60	4.1	7-142-300-301-0	1,702	1,192	596	298
SSB 148	60	4.1	7-148-100-300-0	1,000	715	375	190
SSB 248	60	4.1	7-148-200-300-0	1,910	1,370	720	360
SSB 348	60	4.1	7-148-300-103-0	2,740	1,918	959	479
SSB 260	60	4.1	7-160-200-300-0	4,650	2,340	1,760	880
SSB 360	60	4.1	—	7,030	4,050	2,660	1,330
SSB 460	60	4.1	—	8,500	5,950	2,975	1,488

# Air Tube Disc Clutches and Brakes

## Low Inertia Spring-Set Brake Component Parts

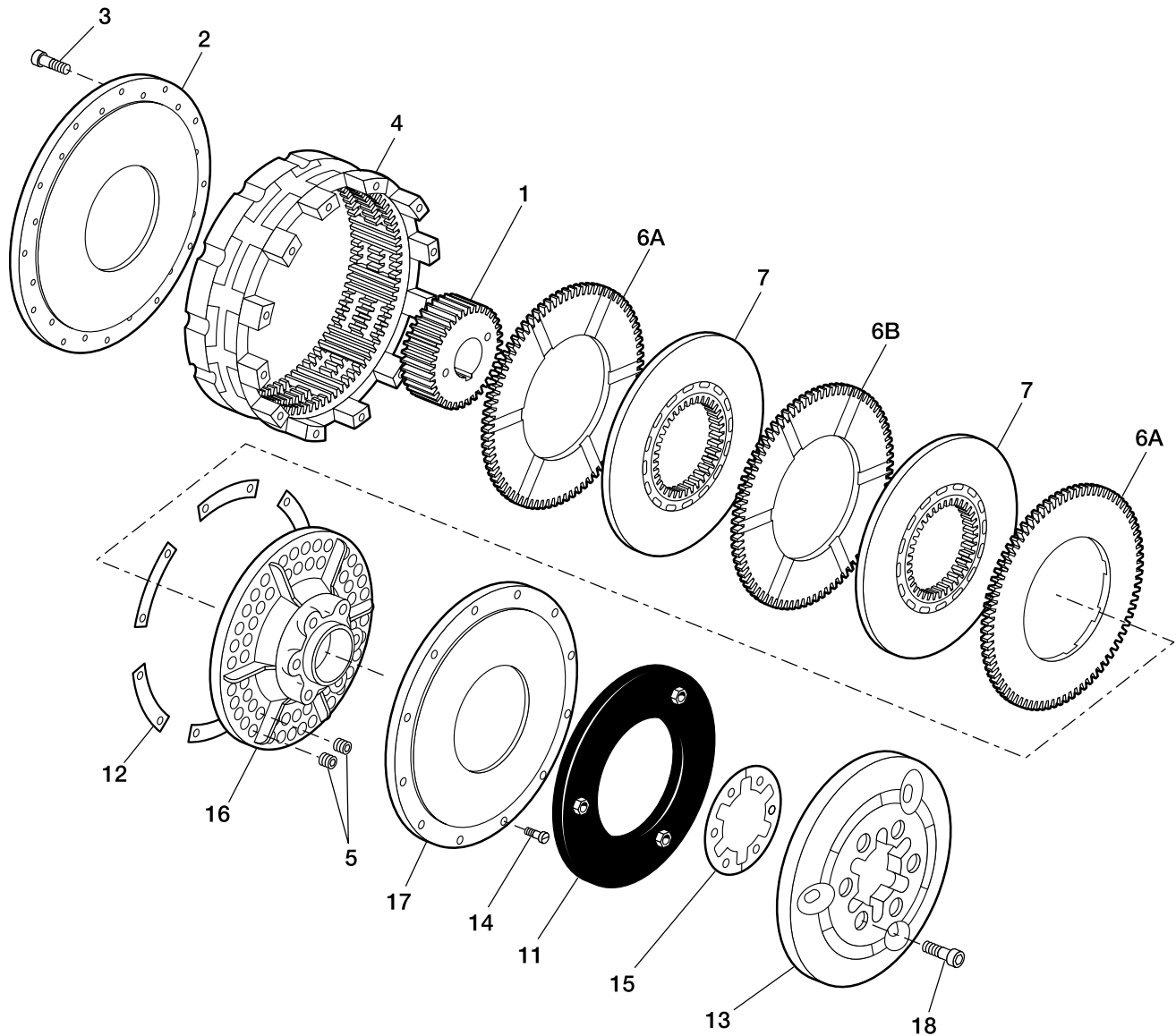

### Component Parts

- |   |                            |
|---|----------------------------|
| 1. Hub  | 11. Airtube                |
| 2. Backplate                                      | 12. O. D. Shims            |
| 3. Socket Head Capscrews                          | 13. Air Tube Holding Plate |
| 4. Ring   | 14. Socket Head Capscrews  |
| 5. Springs  | 15. I.D. Shims             |
| 6A. Grooved Friction Disc (grooved on one side)   | 16. Spring Release Plate   |
| 6B. Grooved Friction Disc (grooved on both sides) | 17. Airtube Spring Plate   |
| 7. Center Plate                                   | 18. Socket Head Capscrews  |

# Air Tube Disc Clutches and Brakes

## Spring-Set Brake Air Hose Kits

B

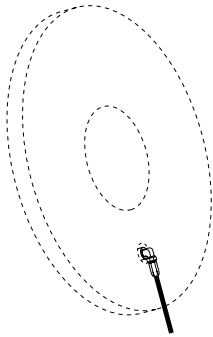

Model	Part Number
8"	8-908-912-100-5 8-908-924-100-5 QRV

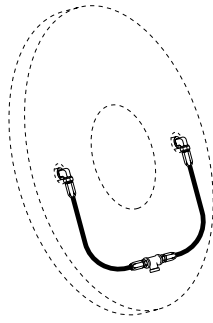

Model	Part Number
6"	8-906-912-200-4 8-906-931-201-5 QRV
8"	8-908-913-200-5 8-908-931-200-5
11"	8-911-913-200-5 8-911-931-200-5 QRV
14"	8-914-913-200-5 8-914-921-200-5 QRV
16"	8-916-913-200-5 8-916-921-200-5 QRV

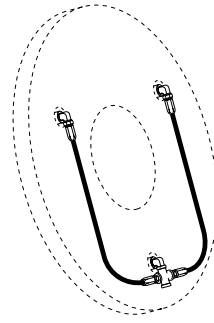

Model	Part Number
18"	8-918-912-200-5 8-918-931-200-5 QRV
21"	8-921-913-200-5 8-921-931-200-5 QRV
24"	8-924-913-200-5 8-924-931-200-5 QRV
27"	8-927-913-200-5 8-927-921-200-5 QRV

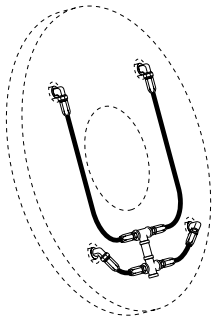

Model	Part Number
30"	8-930-913-400-5 8-930-931-400-5 QRV
36"	8-936-913-400-6 8-936-931-400-6 QRV
42"	8-942-913-400-6 8-924-931-400-6 QRV
48"	8-948-912-400-6 8-948-923-400-6 QRV

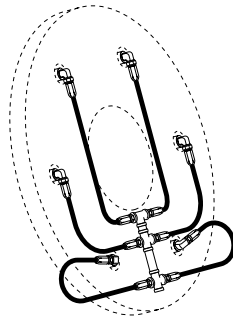

Model	Part Number
60"	8-960-912-500-5 8-960-923-400-6 QRV

Air hose kits contain all necessary parts (fittings, hoses and extensions) to completely plumb the brake air system.

Optional Quick Release Valves can replace elbows on most units (see page 121).





# Air Tube Disc Clutches and Brakes

## Spring-Set Brakes (Sizes 4H, 8-36)

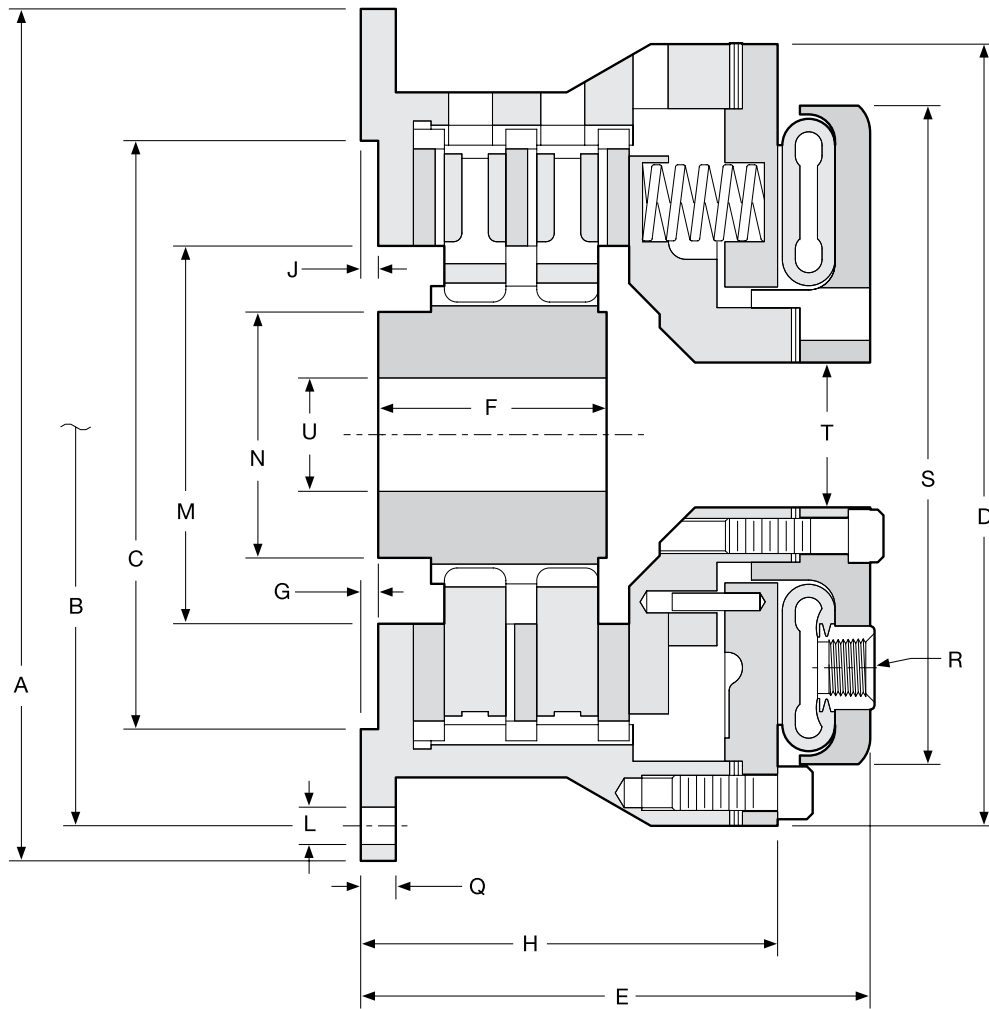

# Air Tube Disc Clutches and Brakes

## Dimensions: inches (mm)

Model	B		C		D	E	F	G	H
Size ATD-	A	Hole Circle	Pilot						
SSB 104H	7.09 (180)	6.496 (165)	5.512 / 5.515 (140.00 / 140.06)		7.09 (180)	4.13 (105)	0.98 (25)	0.06 (1.6)	3.78 (96)
SSB 108	12.13 (308.1)	11.125 (282.58)	8.375 / 8.378 (212.73 / 212.80)		11.13 (282.7)	5.88 (149.4)	2.00 (50.8)	0.25 (6.4)	4.56 (115.8)
SSB 208	16.00 (406.4)	14.750 (374.65)	11.375 / 11.378 (288.93 / 289.00)		14.75 (374.7)	6.56 (166.6)	2.75 (69.9)	0.13 (3.3)	5.44 (138.2)
SSB 211	18.75 (476.3)	17.500 (444.50)	14.375 / 14.378 (365.13 / 365.20)		17.50 (444.5)	8.00 (203.2)	3.00 (76.2)	0.13 (3.3)	6.00 (152.4)
SSB 114	21.25 (539.8)	20.000 (508.00)	16.250 / 16.253 (412.75 / 412.83)		20.00 (508.0)	8.25 (209.6)	4.00 (101.6)	0.38 (9.7)	6.00 (152.4)
SSB 216	23.25 (590.6)	22.000 (558.80)	18.250 / 18.253 (463.55 / 463.63)		22.00 (558.8)	10.06 (255.5)	4.75 (120.7)	0.38 (9.7)	7.87 (199.9)
SSB 316	27.00 (685.8)	25.500 (647.70)	21.375 / 21.378 (542.93 / 543.00)		24.88 (632.0)	12.13 (308.1)	6.63 (168.4)	—	9.88 (251.0)
SSB 118	30.00 (762)	28.750 (730.25)	24.375 / 24.378 (619.13 / 619.20)		29.00 (736.6)	9.00 (228.6)	4.00 (101.6)	0.44 (11.2)	6.56 (166.6)
SSB 218	32.75 (831.9)	31.500 (800.10)	27.375 / 27.378 (695.33 / 695.40)		31.00 (787.4)	10.70 (271.8)	4.75 (120.7)	0.44 (11.2)	8.45 (214.6)
SSB 318	37.00 (939.8)	35.500 (901.70)	30.375 / 30.378 (771.53 / 771.60)		34.75 (882.7)	—	—	—	—
SSB 121	43.50 (1,104.9)	42.000 (1,066.80)	36.375 / 36.378 (923.93 / 924.00)		41.00 (1,041.4)	9.69 (241.6)	4.00 (101.6)	0.75 (19.1)	7.38 (187.5)
SSB 221	—	—	—		—	11.88 (301.8)	5.13 (130.3)	0.75 (19.1)	9.57 (243.1)
SSB 321	—	—	—		—	—	—	—	—
SSB 124H	—	—	—		—	9.56 (242.8)	4.00 (101.6)	0.75 (19.1)	6.50 (165.1)
SSB 224H	—	—	—		—	11.88 (301.8)	5.13 (130.3)	0.81 (20.6)	9.50 (241.3)
SSB 324H	—	—	—		—	—	—	—	—
SSB 127	32.75 (831.9)	31.500 (800.10)	27.375 / 27.378 (695.33 / 695.40)		31.00 (787.4)	9.94 (252.5)	4.50 (114.3)	—	7.69 (195.3)
SSB 227	—	—	—		—	12.5 (317.5)	6.88 (174.8)	0.75 (19.1)	10.13 (257.3)
SSB 327	—	—	—		—	15.25 (387.4)	7.94 (201.7)	—	12.56 (319.0)
SSB 130H	37.00 (939.8)	35.500 (901.70)	30.375 / 30.378 (771.53 / 771.60)		34.75 (882.7)	11.00 (279.4)	5.00 (127.0)	0.63 (16)	8.31 (211.1)
SSB 230H	—	—	—		—	14.75 (374.7)	7.13 (181.1)	1.88 (47.8)	11.75 (298.5)
SSB 330H	—	—	—		—	—	—	—	—
SSB 136H	—	—	—		—	11.75 (298.5)	4.25 (108.0)	0.63 (16)	8.56 (217.4)
SSB 236H	—	—	—		—	15.13 (384.3)	9.00 (228.6)	0.63 (16)	12.00 (304.8)
SSB 336H	—	—	—		—	19.06 (484.1)	12.38 (314.5)	1.00 (25.4)	15.81 (401.6)

## Dimensions: inches (mm)

Model	J	L		M	N	Q	R		S	T	U	
		No. -	Size				No. -	Size			Min.	Max.
SSB 104H	0.19 (4.7)	4 -	0.35 (9)	2.99 (76)	1.97 (50)	2.13 (54)	2 -	1/8 NPT	7.09 (180)	1.97 (50)	0.60 (15)	1.00 (25)
SSB 108	0.25 (6.4)	6 -	17/32 (13.5)	5.38 (136.7)	3.50 (88.9)	0.50 (12.7)	2 -	1/2 NPT	9.38 (238.3)	2.06 (52.3)	1.00 (25)	2.00 (50.8)
SSB 208	0.38 (9.7)	6 -	21/32 (16.7)	7.00 (177.8)	4.00 (101.6)	0.63 (16)	2 -	1/2 NPT	11.94 (303.3)	3.02 (76.7)	1.00 (25)	2.50 (63.5)
SSB 114	0.38 (9.7)	8 -	21/32 (16.7)	9.44 (239.8)	5.50 (139.7)	0.63 (16)	2 -	1/2 NPT	14.38 (365.3)	3.88 (98.6)	1.38 (35.1)	3.50 (88.9)
SSB 214	—	—	—	—	—	—	—	—	—	3.88 (98.6)	—	—
SSB 314	—	—	—	—	—	—	—	—	—	—	—	—
SSB 116	0.38 (9.7)	12 -	11/16 (17.5)	10.50 (266.7)	6.00 (152.4)	0.63 (16)	2 -	1/2 NPT	16.30 (414)	4.38 (111.3)	1.38 (35.1)	4.00 (101.6)
SSB 216	—	—	—	—	—	—	—	—	—	—	—	—
SSB 316	—	—	—	—	—	—	—	—	—	—	—	—
SSB 118	0.38 (9.7)	12 -	21/32 (16.7)	12.50 (317.5)	7.00 (177.8)	0.63 (16)	3 -	1/2 NPT	19.38 (492.3)	4.88 (124)	2.00 (50.8)	4.75 (120.7)
SSB 218	—	—	—	—	—	—	—	—	—	—	—	—
SSB 318	—	—	—	—	—	—	—	—	—	—	—	—
SSB 121	0.31 (7.9)	12 -	21/32 (16.7)	14.50 (368.3)	9.00 (228.6)	0.75 (19.1)	3 -	1/2 NPT	21.31 (541.3)	6.25 (158.8)	2.00 (50.8)	6.00 (152.4)
SSB 221	—	—	—	—	—	—	—	—	—	—	—	—
SSB 321	—	—	—	—	—	—	—	—	—	—	—	—
SSB 124H	0.25 (6.4)	12 -	21/32 (16.7)	14.50 (368.3)	9.00 (228.6)	0.75 (19.1)	3 -	1/2 NPT	26.50 (673.1)	8.25 (209.6)	2.00 (50.8)	6.00 (152.4)
SSB 224H	—	—	—	—	—	—	—	—	—	—	—	—
SSB 324H	—	—	—	—	—	—	—	—	—	—	—	—
SSB 127	0.25 (6.4)	16 -	21/32 (16.7)	16.25 (412.8)	9.00 (228.6)	0.75 (19.1)	3 -	1/2 NPT	27.00 (685.8)	8.25 (209.6)	2.50 (63.5)	6.50 (165.1)
SSB 227	—	—	—	—	—	—	—	—	—	—	—	—
SSB 327	—	—	—	—	—	—	—	—	—	—	—	—
SSB 130H	0.25 (6.4)	18 -	25/32 (19.8)	19.25 (489)	10.00 (254)	0.75 (19.1)	4 -	1/2 NPT	31.94 (811.3)	8.25 (209.6)	2.50 (63.5)	7.25 (184.2)
SSB 230H	—	—	—	—	—	—	—	—	—	—	—	—
SSB 330H	—	—	—	—	—	—	—	—	—	—	—	—
SSB 136H	0.25 (6.4)	18 -	25/32 (19.8)	23.63 (600.2)	12.00 (304.8)	0.88 (22.4)	4 -	1/2 NPT	38.25 (971.6)	12.75 (323.9)	6.00 (152.4)	9.00 (228.6)
SSB 236H	—	—	—	—	—	—	—	—	—	—	—	—
SSB 336H	—	—	—	—	—	—	—	—	—	—	—	—

**Note:** For mounting, use socket head capscrews conforming to the ASTM-574-97a.  
(Consult factory for drawing before final layout.)

# Air Tube Disc Clutches and Brakes

## Spring-Set Brakes (Sizes 6, 42-48)

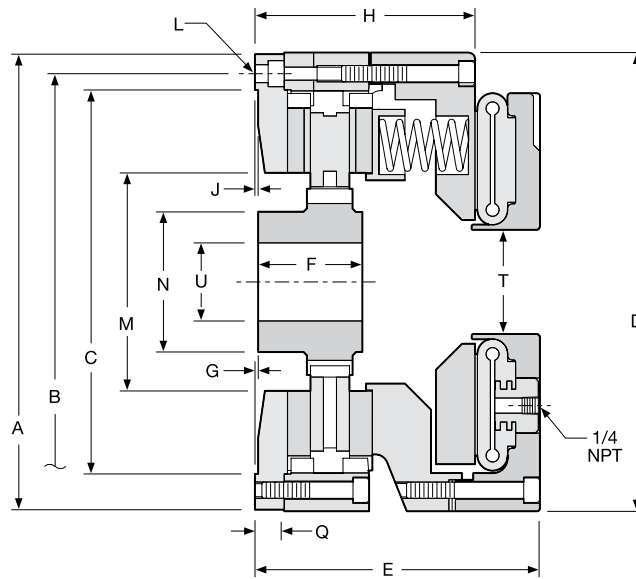

Size 6

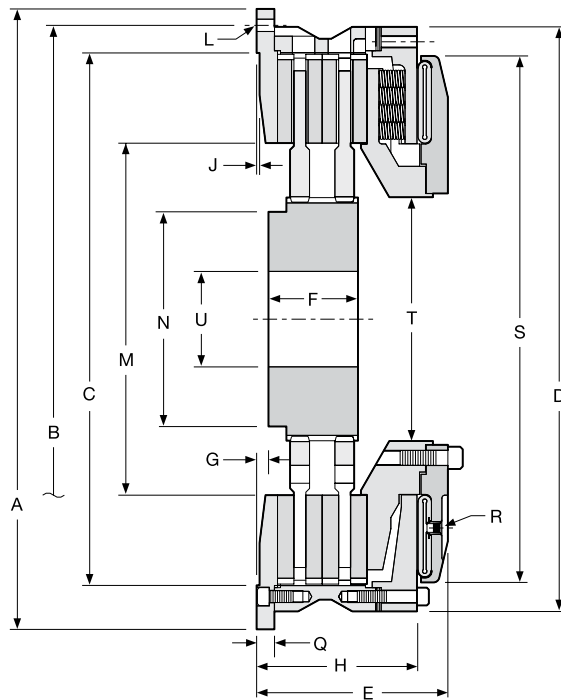

Sizes 42-48

# Air Tube Disc Clutches and Brakes

## Dimensions: inches (mm)

Model	B		C	D	E	F	G	H
Size ATD-	A	Hole Circle	Pilot					
SSB 106	8.75	8.000	7.377 / 7.379	8.81	5.47 (138.9)	2.00 (50.8)	0.00 (0.0)	4.22 (107.2)
SSB 206	(222.3)	(203.20)	(187.38 / 187.43)	(223.8)	6.66 (169.2)	3.25 (82.6)	0.06 (1.5)	5.44 (138.2)
SSB 142	52.00	49.250	44.625 / 44.628	49.00	12.28 (311.9)	5.63 (143.0)	1.00 (25.40)	9.69 (246.1)
SSB 242	(1,320.8)	(1,250.95)	(1,133.48 / 1,133.55)	(1,244.6)	16.03 (407.2)	7.50 (190.5)		13.44 (341.4)
SSB 148	61.00	58.000	52.000 / 52.005	56.75	15.00 (381.0)	6.00 (152.4)	0.00 (0.0)	11.19 (284.2)
SSB 248	(1,549.4)	(1,473.20)	(1,320.80 / 1,320.93)	(1,441.5)	19.33 (491.0)	8.75 (222.3)	1.00 (25.4)	15.5 (393.7)
SSB 260 <sup>1</sup>	70.50	66.500	62.750 / 62.760	70.50	22.31 (566.7)	9.38 (238.3)	0.25 (6.40)	17.61 (447.3)
SSB 360 <sup>1</sup>	(1,790.7)	(1,689.10)	(1,593.85 / 1,594.10)	(1,790.7)	26.88 (682.8)	14.13 (358.9)		22.25 (565.2)

## Dimensions: inches (mm)

Model	L		R			U				
Size ATD-	J	No. - Size	M	N	Q	No. - Size	S	T	Min.	Max.
SSB 106	0.06	4 - 0.34 (8.6)	4.19	2.69	0.56	2 - 1/4 NPT	—	2.00	0.60	2.00
SSB 206	(1.5)		(106.4)	(68.3)	(14.2)			(50.8)	(15.2)	(50.8)
SSB 142	0.25	24 - 1.06 (26.9)	29.50	18.00	1.50	4 - 1/2 NPT	44.13	20.44	8.00	14.00
SSB 242	(6.4)		(749.3)	(457.2)	(26.9)		(1,102.9)	(519.2)	(203.2)	(355.6)
SSB 148	0.25	24 - 1.06 (26.9)	32.00	25.75	1.50	4 - 1/2 NPT	52.13	19.00	10.00	18.00
SSB 248	(6.4)		(812.8)	(654.1)	(38.1)		(1,324.1)	(482.6)	(254.0)	(457.2)
SSB 260 <sup>1</sup>	0.25	24 - 4.5" NC	36.00	27.00	—	6 - 1/2 NPT	61.50	20.63	11.00	19.00
SSB 360 <sup>1</sup>	(6.4)		(914.4)	(685.8)			(1,562.1)	(524.0)	(279.4)	(482.6)

<sup>1</sup> Less backplate.

**NOTE:** For mounting, use socket head capscrews conforming to the ASTM-574-97a.  
(Consult factory for drawing before final layout.)