

VKSD Spring Applied – Hydraulically Released

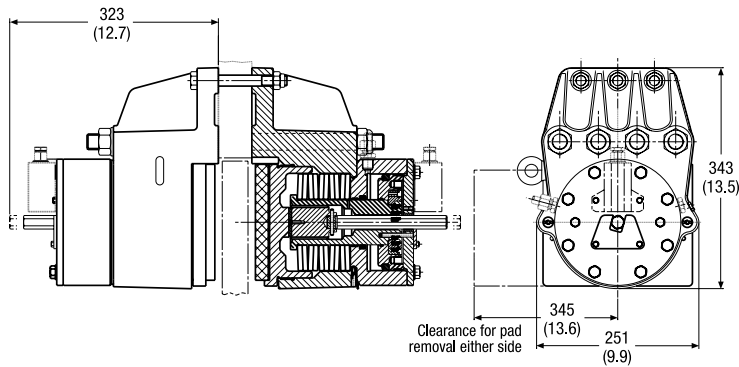

The Twiflex VKSD disc brake caliper is comprised of two halves, or spring modules, and is suitable for use with a minimum disc thickness of 20mm (0.79 in). The modules are mounted each side of a central mounting plate 12mm (0.47 in) thicker than the brake disc. Minimum disc diameter is 1000mm (39.37 in).

Normally one or two calipers are used per disc, but the number may be increased depending on disc size. The brakes may be positioned at any angle around the periphery of the disc, but should ideally be mounted horizontally (i.e. at the 3 o'clock or 9 o'clock position). A range of brake discs is available from Twiflex (see Disc and Hub Assemblies).

Braking force ratings are achieved through a combination of different springs, shims and air gap settings. Spring fatigue life is a function of the caliper rating.

The ratings shown in the table are based on fully bedded in and conditioned brake pads with a nominal friction coefficient $\mu = 0.4$. Twiflex disc brakes must be used with Twiflex asbestos free brake pads.

Effective disc radius = actual radius (m) – 0.095m
(Effective disc radius = actual radius (ft) – 0.31 ft)

Caliper Type	Disc/Pad Air Gap mm (in)	Braking Force kN (lb)	Minimum Pressure for Full Retraction bar (psi)
VKSD119	2 (0.08)	119 (26752)	138 (2002)
VKSD112	2 (0.08)	112 (25179)	131 (1900)
VKSD104	2 (0.08)	104 (23380)	124 (1798)
VKSD96	2 (0.08)	96 (21582)	116 (1682)
VKSD88	2 (0.08)	88 (19783)	108 (1566)
VKSD80	2 (0.08)	80 (17985)	100 (1450)
VKSD71	2 (0.08)	71 (15961)	92 (1334)
VKSD62	2 (0.08)	62 (13938)	83 (1204)
VKSD58	2 (0.08)	58 (13039)	63 (914)
VKSD53	2 (0.08)	53 (11915)	58 (814)
VKSD47	2 (0.08)	47 (10566)	53 (769)
VKSD41	2 (0.08)	41 (9217)	47 (682)
VKSD34	2 (0.08)	34 (7644)	41 (595)
VKSD28	2 (0.08)	28 (6295)	34 (493)

Weight of caliper (2 modules) - 146kg (321.87 lb)
Volume displacement per 1mm (0.04 in) stroke at both pads = 28ml (0.95 fl oz)

VKSD-FL Spring Applied – Hydraulically Released

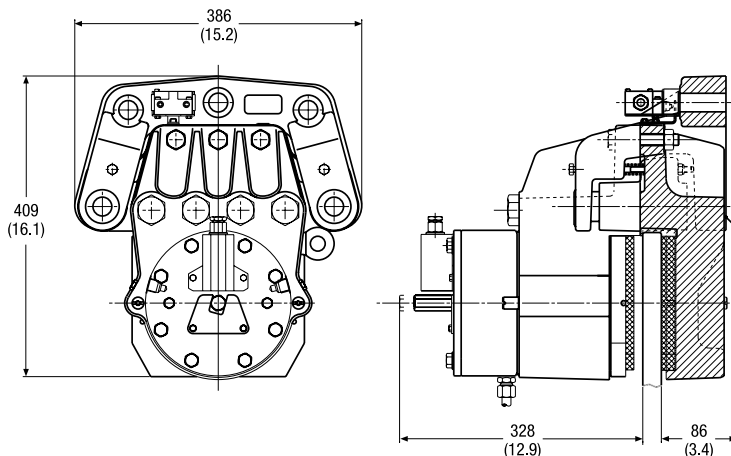

The Twiflex VKSD-FL disc brake caliper comprises a single spring module forming the 'active' side of this floating unit and is available for use where space is limited or to accommodate axial disc float of ± 6 mm (0.24 in).

Braking force ratings are achieved through a combination of different springs, shims and air gap settings. Spring fatigue life is a function of the caliper rating.

The ratings shown in the table are based on fully bedded in and conditioned brake pads with a nominal friction coefficient $\mu = 0.4$. Twiflex disc brakes must be used with Twiflex asbestos free brake pads.

Effective disc radius = actual radius (m) – 0.095m
(Effective disc radius = actual radius (ft) – 0.31 ft)

Retraction pressures where shown are calculated and may vary depending on spring tolerance.