

# CH Series Multiple Disc Clutches and Brakes

Hydraulic/Pneumatic



- Industrial
- Marine
- Oil Field
- Mining
- Construction



 **Logan Clutch Corporation**<sup>®</sup>  
manufacturers of clutches and brake products

Family owned and operated since 1975, Logan offers a complete line of fluid / air actuated multiple disc clutches, brakes, PTO Clutches and clutch discs for a variety of wet and dry clutch and brake applications.

**Markets include:** Machine Tool, Industrial, Marine, Irrigation, Rail, Oil Field, and Off-Highway industries.

**Applications include:** Pump Drives, Trenchers, Tunnel Boring and Snow Removal Equipment, Single and Multi-Speed Transmissions, Marine Transmissions, Work Boats, Escort Vessels, Marine Z-drives, Machine Tools, Screw Machines, Conventional and High Performance friction and steel clutch discs.

Logan Sales, Engineering and Customer service personnel are available to answer questions regarding catalog specs, parts and service details, and inquiries regarding your specific design requirements. We certainly thank you for your interest, and look forward to being of further service.



## CH Series Description

Type CH clutches are designed specifically for heavy duty clutch and brake applications, and can be air or hydraulically actuated.

The friction disc packs are suitable for either wet or dry operation. Actuation is accomplished through internal shaft and clutch passages.

When used as a wet clutch, coolant oil may be used as a splash or spray, or forced through the friction disc pack from an internal shaft passage.

The clutch hub is bored and keyseated for shaft mounting. Torque is transferred from the disc pack to a splined drive ring.

### Operation:

Pressurizing the cylinder with fluid or air forces the piston to clamp and lock the friction and separator discs, and release springs. Torque is transferred through the clutch to the drive cup. When pressure is removed, the release springs separate the separator discs and maintain a running clearance between separator and friction disc surfaces.

### Standard Specifications:

Type CH clutches are available in seven sizes with torque ratings from 49,000 lb-in (5532 Nm) to 1,280,000 lb-in (144,000 Nm).

Maximum allowable pressure is 200 psi (13,8 bar) for wet operation and 120 psi (8,3 bar) for dry operation.

Standard operating speeds are from 1 to 2200 RPM. Stronger release springs are available for disengagement at higher speeds.

### Modified Standards:

Higher torque ranges and actuation pressures are available to meet customer's specific design requirements.

## Advantages:

### American Bureau of Shipping (ABS) Type Approval

Survey society approved for marine applications requiring independent survey. Other classification society certifications such as Lloyd's and DNV are also available.



### Where used:

- Marine Propulsion
- Marine Mooring Winches
- Mine Hoisting Equipment
- Overland Mining Conveyors
- Draw Works
- Fan Drives

### Self Lubricating Seals

Long-wearing, self-lubricating seals minimize premature twisting failure and require no lubrication, which decreases maintenance costs and downtime. Temperature ranges for standard seals range from -65°F to +300°F (-54°C to +149°C).

### Long Wearing Components:

The cylinder housing and all splined surfaces are specially treated to minimize wear and increase corrosion resistance.

### Positive Mechanical Lock-Up "Come Home" Feature:

Provides positive engagement for emergency operation.

### Smooth Engagement:

Sintered Bronze Friction Material, operating in oil, provides a low static-to-dynamic torque ratio for smooth, long-lasting, high-energy performance.



# CH 1050-CH 2150 Component Parts

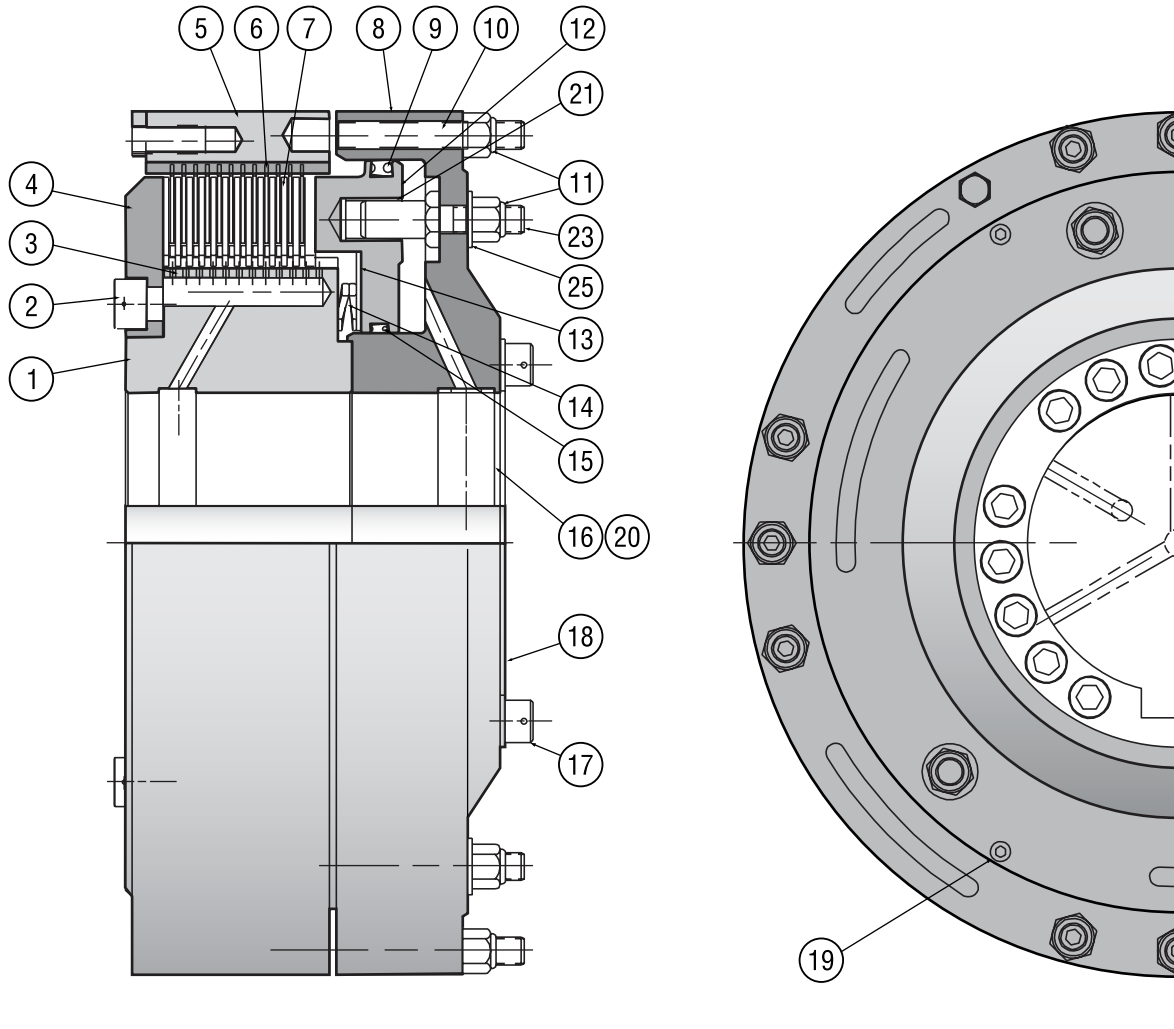

Item	Description
1	Hub
2	Socket Head Cap Screw
3	Separator Spring
4	End Plate
5	Drive Ring
6	Separator Disc
7	Friction Disc
8	Cylinder
9	Seal
10	Mechanical Lock-Up Screw
11	Locknut
12	Piston

Item	Description
13	Spring Retainer
14	Spring
15	Seal
16	Shaft Seal-Pressure
17	Socket Head Cap Screw
18	Clamp Plate
19	Pipe Plug
20	Shaft Seal-Balance
21	Bushing
23	Anti-Rotation Pin
25	Flat Washer

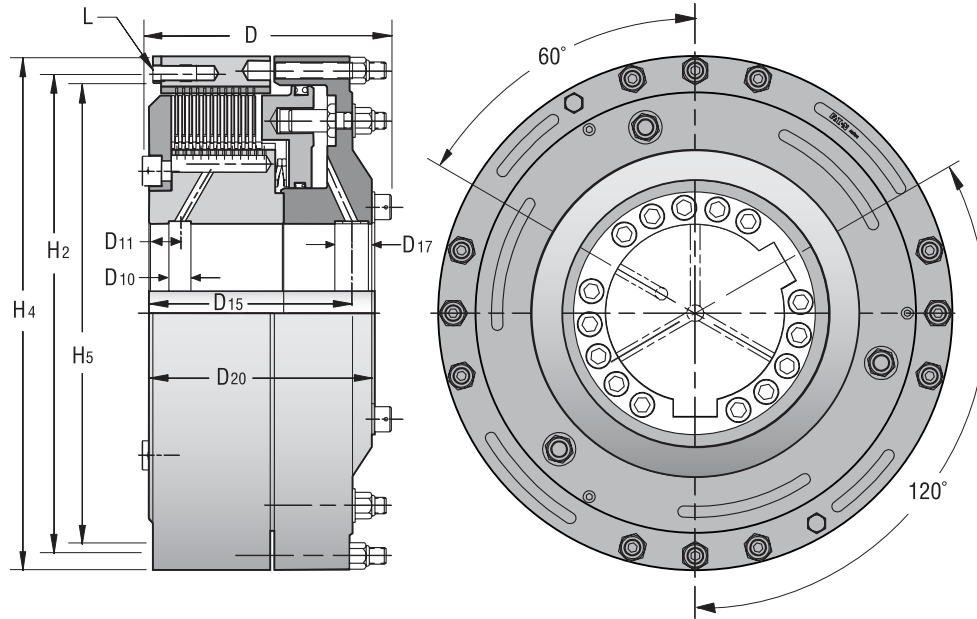

English	Dimensions in inches												⑦ CH Clutch Weight	
													Material	Weight (lbs.)
CH1050	3.38	7.88	.63	1.00	6.34	375	7.13	12.000	13.00	11.375	12	1/2-13	Steel	185
													Aluminum	135
CH1250	4.50	8.75	.75	1.53	7.19	1.25	8.00	14.375	15.50	13.583	15	1/2-13	Steel	291
													Aluminum	185
CH1440	5.25	10.37	.75	1.50	8.56	1.25	9.38	16.500	17.75	15.625	15	5/8-11	Steel	475
													Aluminum	350
CH1640	6.25	10.62	.75	1.50	8.77	1.25	9.63	18.500	19.75	17.562	18	5/8-11	Steel	567
													Aluminum	450
CH1940	8.00	11.16	1.25	1.50	9.07	1.50	9.98	21.500	23.00	20.625	15	3/4-10	Steel	830
													Aluminum	685
CH2150	9.00	11.38	1.38	1.69	10.40	1.50	11.33	23.750	25.50	22.625	18	3/4-10	Steel	1080
													Aluminum	822
Size	Max. Bore	D	D <sub>10</sub>	② D <sub>11</sub>	② D <sub>15</sub>	D <sub>17</sub>	D <sub>20</sub>	H <sub>2</sub>	H <sub>4</sub>	H <sub>5</sub>	③ No. No.	① Size L Size	⑦ CH Clutch Weight	Weight (Kg.)
CH1050	86	200	16	25	161	9.5	181	304.8	330	288.9	12	1/2-13	Steel	84
													Aluminum	62
CH1250	114	222	19	39	182.6	31.8	203	365.1	394	345.0	15	1/2-13	Steel	132
													Aluminum	84
CH1440	133	263	19	38	217.4	31.8	238	419.1	451	396.9	15	5/8-11	Steel	215
													Aluminum	159
CH1640	159	270	19	38	227.8	31.8	244	469.9	502	446.1	18	5/8-11	Steel	257
													Aluminum	204
CH1940	203	283	32	38	230.4	38.1	253	546.1	584	523.9	15	3/4-10	Steel	376
													Aluminum	311
CH2150	229	289	35	43	264.2	38.1	287	603.3	648	574.7	18	3/4-10	Steel	490
													Aluminum	373
SI	Dimensions in millimeters													

**Notes:**

- ① Unified National Standard - UNS.
  - ② The centerline location is based on the maximum bore diameter. This location will change with bore dimensions less than the maximum.
  - ③ Specifies outer register dimensions.
- \* Data shown is subject to change. Please consult factory for current dimensional data.



# CH Elements – Technical Data for Wet or Dry Operation

## Wet Operation

Size	Part Number	lb•in @ 150 psi	lb•in ⓐ @200 psi	rpm	rpm	ft lb/cycle	Typical		Maximum	
							HP	GPM	HP	GPM
CH1050	146194	100000	140000	2200	1000	400000	30	5	60	10
CH1250	146196	180000	250000	2000	1000	530000	40	7	80	14
CH1440	146203	270000	400000	1800	800	680000	52	9	104	18
CH1640	146204	390000	540000	1600	800	820000	64	11	128	22
CH1940	146250	580000	890000	1300	500	1130000	93	16	186	32
CH2150	146206	830000	1280000	1200	400	1630000	134	23	268	46

Size	Part Number	M <sub>r</sub> ⓑ Torque Rating	Maximum Speed	Maximum Disengaged Speed	Maximum Work/Cycle	Power		Oil Flow		
						Power	Oil Flow	Power	Oil Flow	
CH1050	146194	11300	15750	2200	1000	542000	22	19	45	38
CH1250	146196	20300	28100	2000	1000	719000	30	26	60	53
CH1440	146203	30500	45000	1800	800	922000	39	34	76	68
CH1640	146204	44100	60700	1600	800	1112000	48	42	95	83
CH1940	146250	65500	100100	1300	500	1532000	69	61	139	121
CH2150	146206	93800	144000	1200	400	2210000	100	87	200	174

SI	N•m @10.3 bar	N•m @13.8 bar	rpm	rpm	joule/cycle	kW		L/min	
						Typical	Maximum	Typical	Maximum
CH1050	11300	15750	2200	1000	542000	22	19	45	38
CH1250	20300	28100	2000	1000	719000	30	26	60	53
CH1440	30500	45000	1800	800	922000	39	34	76	68
CH1640	44100	60700	1600	800	1112000	48	42	95	83
CH1940	65500	100100	1300	500	1532000	69	61	139	121
CH2150	93800	144000	1200	400	2210000	100	87	200	174

## Dry Operation

Size	Part Number	lb•in @90 psi	lb•in ⓐ @120 psi	rpm	ft. lb/cycle	HP					
						1000 fpm	2000 fpm	3000 fpm	1000 fpm	2000 fpm	3000 fpm
CH1050	146194	100000	139000	2200	80000	1	5	11	1	3	8
CH1250	146196	180000	240000	1800	110000	1	6	15	1	4	10
CH1440	146203	270000	380000	1800	140000	2	8	19	1	5	13
CH1640	146204	390000	500000	1600	160000	2	10	23	1	6	16
CH1940	146250	580000	820000	1300	230000	3	14	32	2	9	21
CH2150	146206	830000	1200000	1200	330000	4	20	46	3	13	31

Size	Part Number	M <sub>r</sub> ⓑ Torque Rating	Torque Rating	Max. Speed	Max. Work/cycle	Clutch Thermal Capacity ⓑ			Brake Thermal Capacity ⓓ		
						5.08 mps	10.16 mps	15.24 mps	5.08 mps	10.16 mps	15.24 mps
CH1050	146194	11300	15600	2200	108000	0.75	3.7	8.2	0.75	2.2	6.0
CH1250	146196	20300	27000	1800	149000	0.75	4.5	11	0.75	3.0	7.5
CH1440	146203	30500	42700	1800	190000	1.5	6.0	14	0.75	3.7	9.7
CH1640	146204	44100	56200	1600	217000	1.5	7.5	17	0.75	4.5	12
CH1940	146250	65500	92200	1300	312000	2.2	10	24	1.5	6.7	16
CH2150	146206	93800	135000	1200	447000	3.0	15	34	2.2	9.7	23

SI	N•m @ 6.2 bar	N•m @8.3 bar	rpm	joule/cycle	kW					
					1000 fpm	2000 fpm	3000 fpm	1000 fpm	2000 fpm	3000 fpm
CH1050	11300	15600	2200	108000	0.75	3.7	8.2	0.75	2.2	6.0
CH1250	20300	27000	1800	149000	0.75	4.5	11	0.75	3.0	7.5
CH1440	30500	42700	1800	190000	1.5	6.0	14	0.75	3.7	9.7
CH1640	44100	56200	1600	217000	1.5	7.5	17	0.75	4.5	12
CH1940	65500	92200	1300	312000	2.2	10	24	1.5	6.7	16
CH2150	93800	135000	1200	447000	3.0	15	34	2.2	9.7	23

A pressure regulating valve should be specified in the system to prevent over-pressurization of any Logan Clutch PTO. The Logan warranty does not cover clutch failure due to over and under pressurization. The highest pressure values in the torque tables are maximum ratings for Logan Clutches. Maximum clutch torque may be limited by customers' choice in shaft material strength. It is the customers responsibility to verify shaft strength when using Logan CH clutches.

All rotating components present a potentially hazardous condition and should be guarded in accordance with OSHA requirements and other applicable laws, regulations and industrial standards.

Logan Clutch Corporation reserves the right to modify product specifications and designs without notice and without incurring obligations. Torque values are based upon wet or dry disc packs having full contact between surfaces.



English	lb•ft <sup>2</sup>		lb	E+08•lb•in/rad	in <sup>3</sup>		in <sup>2</sup>
	Drive Ring & Friction Disc	Assembly Total			Drive Ring & Friction Disc	New	
CH1050	12	23	53	4	32	60	772
CH1250	29	52	90	7	45	90	1013
CH1440	53	102	122	13	79	130	1194
CH1640	82	161	151	18	101	166	1631
CH1940	137	293	183	33	143	301	2061
CH2150	198	529	289	47	185	390	3104

Size	Wk2	④		Torsional Stiffness	Cylinder Volume ⑤		Friction Area
	J						
CH1050	0.51	0.97	117	0.452	0.52	0.98	4981
CH1250	1.22	2.19	198	0.791	0.74	1.48	6536
CH1440	2.33	4.30	270	1.47	1.29	2.13	7703
CH1640	3.45	6.78	333	2.03	1.66	2.72	10523
CH1940	5.77	12.34	403	3.73	2.34	4.93	13297
CH2150	8.34	22.29	636	5.31	3.03	6.39	20026

SI	Drive Ring	Hub & Cylinder	Drive Ring	E+08•N•m/rad	New	Worn	cm <sup>2</sup>
	kg•m <sup>2</sup>				dm <sup>3</sup>		

**Notes:**

- ❶ Dynamic torque shown. Static torque 25% greater.
- ❷ Based upon an ambient air temperature of 100°F (38°C). Speeds are at friction disc outside diameter.
- ❸ Coolant to be type C3 approved or EP oils suitable for CC or SE service within a viscosity range of SAE10 to SAE50W with no free chlorine or free sulphur. Thermal capacities based on 100°F (38°C) sump temperature and a maximum temperature rise of 100°F (55°C).
- ❹ Based on maximum bore and aluminum cylinder.
- ❺ Absolute cylinder volume with new or worn friction linings.
- ❻ Higher torque ranges, actuation pressures, and stronger release springs are available to meet customer’s specific design requirements. Contact Logan for more details.
- ❼ Weight based on cylinder piston arrangements made from either Aluminum or Steel.

**Modified Standards Available**

Higher torque ranges, actuation pressures, and stronger release springs are available to meet customer’s specific design requirements. Contact Logan for more details.

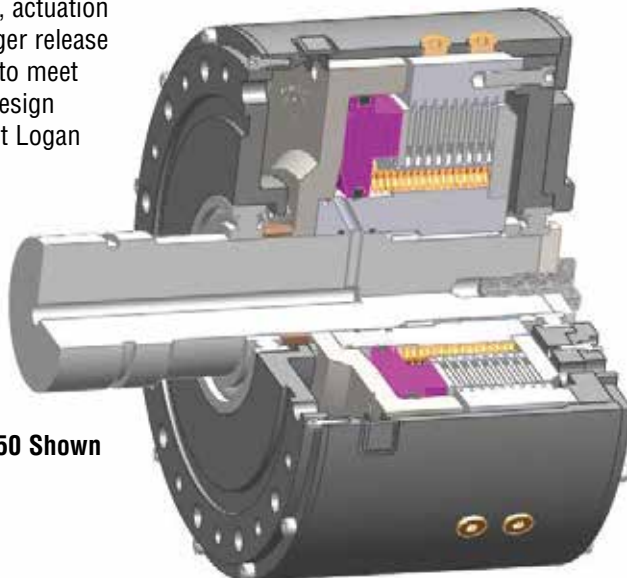

Modified CH 1250 Shown

\* Data shown is subject to change. Please consult factory for current dimensional data.

Suggested Service Factor Table	
Duty	SF
Small Inertia Low Cycle Rate Non-pulsating Load	1.3 to 1.7
Large Inertia Low Cycle Rate Non-pulsating Load	1.7 to 2.2
Small Inertia High Cycle Rate Pulsating Load	2.2 to 3.2





## Selection Procedures

- I Calculate the torque requirement for the application using one of the following formula

$$\text{Torque (Lb./In.)} = \frac{\text{HP} \times 63025}{\text{RPM}} \quad \text{or} \quad \text{Tc (Nm.)} = \frac{\text{HP} \times 9550}{\text{RPM}}$$

- II Identify the service factor which best identifies your application from the suggested service factor table.

- III Adjust the torque requirement using the selected service factor.

Clutch/Brake Torque Capacity (Tc or Tb) =

$$\frac{\text{Gross Torque Capacity (T)}}{\text{Safety Factor (SF)}}$$

$$T = Tc \times SF \quad \text{or} \quad T = Tb \times SF$$

- IV. Determine if the model will:

- 1) Accommodate the shaft and key
- 2) Operate at the required speed
- 3) Fit within the available space

- V. Determine the Drive Ring Mounting

- VI. Complete the Application Fact Sheet provided in this brochure or complete online at [www.loganclutch.com](http://www.loganclutch.com). Call, e-mail, or Fax your application and place your order.

HP = Horsepower  
 RPM = Clutch or Brake shaft speed  
 WR2 = Total inertia to be stopped (lb.ft.<sup>2</sup>)  
 T = Required Torque (Lb./ Ft., Nm, Lb./in)  
 Tc = Clutch Torque (Lb./ Ft., Nm, Lb./in)  
 Tb = Brake Torque (Lb./ Ft., Nm, Lb./in)  
 t = Time to stop (seconds)  
 SF = Service Factor

## Torque & Horsepower Formulas

$$\text{HP} = \frac{\text{T(Lb./Ft.)} \times \text{RPM}}{5250}$$

$$\text{Torque (Lb./Ft.)} = \frac{\text{HP} \times 5250}{\text{RPM}}$$

$$\text{HP} = \frac{\text{T(Lb./In.)} \times \text{RPM}}{63025}$$

$$\text{Torque (Lb./In.)} = \frac{\text{HP} \times 63025}{\text{RPM}}$$

$$\text{kW} = \frac{\text{T(Nm.)} \times \text{RPM}}{9550}$$

$$\text{Torque (Nm.)} = \frac{\text{kW} \times 9550}{\text{RPM}}$$

### Torque Conversion Calculators

### Multiplier

Newton meters (Nm.) to Pound inches (lb. in.)	8.851
Pound inches (lb. in.) to Newton meters (Nm.)	0.113
Newton meters (Nm.) to Pounds feet (lb. ft.)	0.738
Pounds feet (lb. ft.) to Newton meters (Nm)	1.356

### Horsepower Conversion Calculators

### Multiplier

Horsepower (HP) to kW (Kilowatt)	.7457
Kilowatt (kW) to Horsepower (HP)	1.341

### Volume

### Multiplier

Gallons (G) to Liters (L)	3.785
Liters (L) to Gallons (G)	.2642

### Measurement Conversion Table

### Multiplier

Millimeters (mm) to Inches (in)	.03937
Inches (in) to Millimeters (mm)	25.4

### Pressure Conversion Table

### Multiplier

Bar to pounds per square inch (psi)	14.5
Pounds per square inch (psi) to Bar	0.068

### Weight Conversion Table

### Multiplier

Pounds (lbs.) to Kilograms (Kg.)	0.453
Kilograms (Kg.) to Pounds (lbs.)	2.205





## Element Torque Adjustment

CH torque ratings  $M_r$  must be adjusted for operating pressure  $P_o$  and parasitic loss  $P_p$ . Maximum allowable operating pressure should not exceed the values listed in the following table

### Maximum Allowable Pressure

Type	Wet Operation		Dry Operation	
	English, PSI	SI BAR	English PSI	SI BAR
CH	200	13.8	120	8.3

The elements have an inherent parasitic pressure  $P_p$  which represents the pressure to overcome internal friction and disc pack release springs. Parasitic pressures are given in the following table and must be deducted from the rated pressure and operating pressure.

### Parasitic Pressure $P_p$

Type	English PSI	SI BAR
CH	30	2.0

Adjusted element torque  $M_e$  is then calculated from:

$$M_e = \frac{P_o - P_p}{P_r - P_p} \cdot M_r$$

The adjusted element torque  $M_e$  must then be equal to or greater than the required clutch torque  $M_c$ .

## Operating Speed

Consideration must be given to the maximum disengaged speed for CH elements. If the speeds given on the catalog data page are exceeded, centrifugal force will maintain a fluid head in the actuating cylinder, causing the disc pack to remain engaged.

## Thermal Capacity

Clutch thermal capacity is greatly influenced by the method used to cool the disc pack. Coolant can be sprayed or splashed on the outside of the disc pack, or it can be forced out through the disc pack by means of an internal shaft passage and cross drilling in the hub. The preferred method is forced cooling. However, the most commonly used methods are sprayed or splashed. Clutches can also be operated partially submerged in oil. However, care must be taken to ensure that the fluid level and speed of rotation do not combine to generate excessive heat through churning of the fluid.

Thermal capacities  $P_r$ , for CH elements for wet and dry service are given on their respective data sheets.

Wet thermal capacities are based upon a coolant sump temperature  $T_s$  of 100°F (38°C) and a maximum outlet coolant temperature of 200°F (98°C).

Capacities at other sump temperature can be calculated from:

$$P = P_r \cdot \left[ \frac{200 - T_s (\text{°F})}{100} \right] \text{ (HP)} \quad \text{OR} \quad P = P_r \cdot \left[ \frac{93 - T_s (\text{°C})}{55} \right] \text{ (kW)}$$

With the element engaged, coolant pressure at the inlet should fall within the range of 20 psi (1,4 bar) minimum and 40 psi (2,8 bar) maximum. Coolant should be a type C3 approved oil or SAE10W to SAE50 oil suitable for CC or SE service.

Air cooled thermal capacities are based up an ambient air temperature  $T_s$  of 100°F (38°C). Capacities at other ambient temperatures can be calculated from the formula given above for wet thermal capacities. Air cooled thermal capacities are also a function of operating speed. Values are given for various peripheral velocities at the friction disc outside diameter. Disc diameter in inches can be calculated by dividing the element size by 100. For instance, the CH1050 had a friction disc diameter of 1050/100 = 10.50 inches.



## I. Hydraulic Actuation Wet or Dry Operation

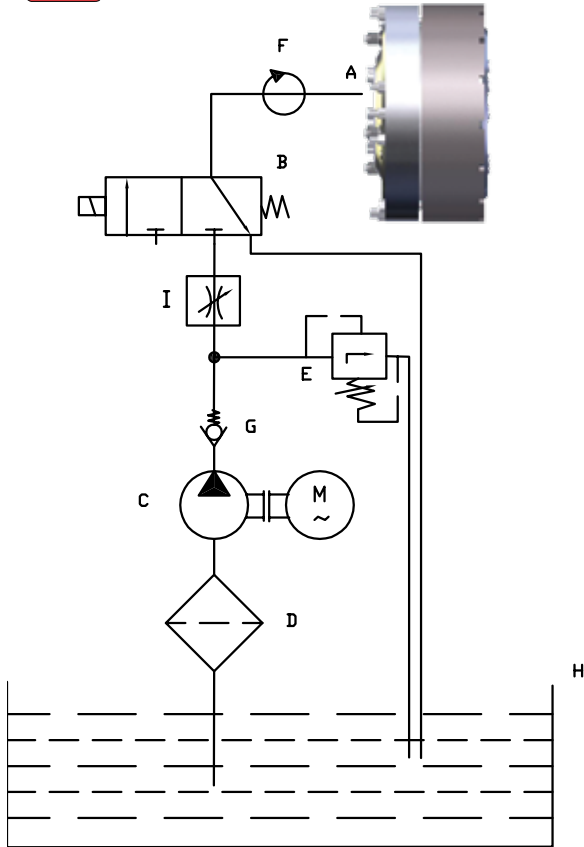

Schematic # 1: Displays a typical circuit diagram for a hydraulically actuated wet or dry-running disc clutch. The pump (C) draws the oil through the filter (D) from the reservoir (H) and passes it under pressure to the operating pipeline. The operating pressure is adjusted by the limiting valve (E). Any excess oil flows back to the reservoir. The clutch (A) is operated when the “ON” position of the control valve (B) is selected.

- A. Clutch
- B. 3/2 Control Valve
- C. Fixed Displacement Pump
- D. Filter
- E. Pressure Limiting Valve
- F. Rotary Connection
- G. Non-Return Valve
- H. Oil Reservoir
- I. Trottle Valve

## II. Pneumatic / Air Actuation Dry Operation

Schematic # 2: Displays a typical circuit diagram for a pneumatically actuated, dry clutch. The accumulator (G), enables fast actuation, and should be installed as close as possible to the clutch. The accumulator's capacity is determined by the volume of the piping, fittings and the cylinder-piston volume of the clutch used in the application.

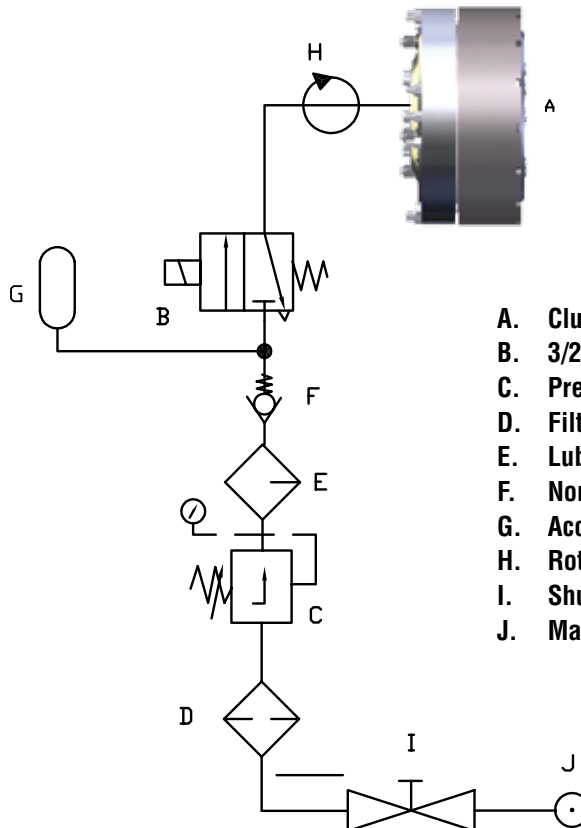

- A. Clutch
- B. 3/2 Control Valve
- C. Pressure Limiting Valve
- D. Filter
- E. Lubricator
- F. Non-Return Valve
- G. Accumulator
- H. Rotary Connection
- I. Shut-off Valve
- J. Main Supply



### III. Hydraulic Actuation Wet operation with through shaft oil lubrication

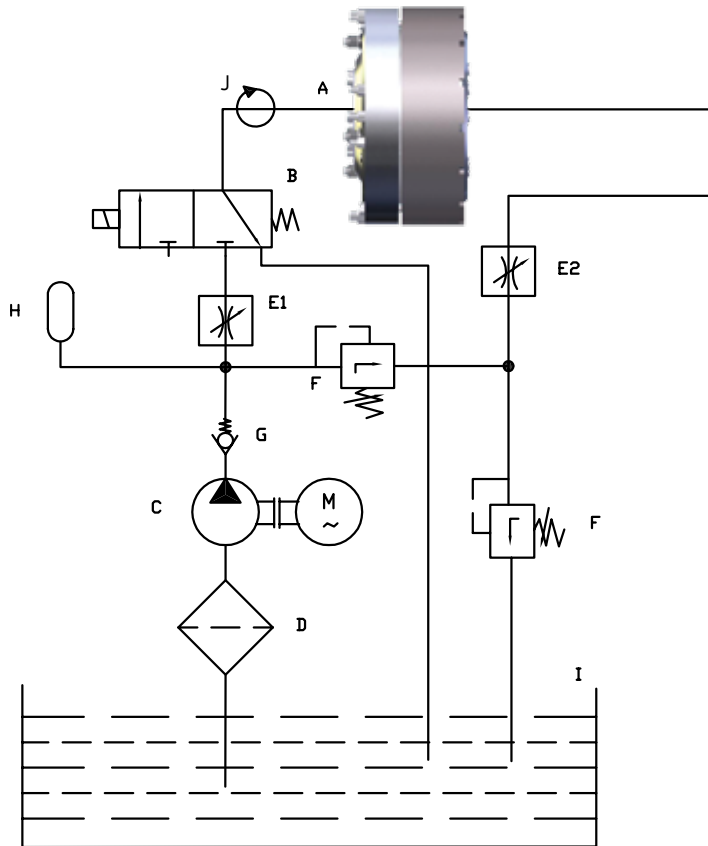

Schematic # 3: Displays a typical circuit diagram for a hydraulically actuated clutch with through shaft lubrication directed at the disc pack. During engagement, the excess oil flows through a cross drilled port through the shaft of the clutch. The throttle valve (E2) acts as the regulator of coolant flow.

- A. Clutch
- B. 3/2 Control Valve
- C. Fixed Displacement Pump
- D. Filter
- E1. and E2. Throttle Valve
- F. Pressure Limiting Valve
- G. Non-Return Valve
- H. Accumulator
- I. Oil Reservoir
- J. Rotary Connection

### IV. Hydraulic Actuation Wet operation with intensive through shaft oil lubrication

Schematic # 4: Displays a typical circuit diagram for clutches with separate actuation and coolant/lubrication sections. When not engaged, a small amount of coolant flows through the throttle valve (E2) to the disc pack. During engagement, the control valves (B & F) are activated at the same time, resulting in a large volume of coolant being introduced. The coolant flows through the 2/2 control valve (F) directly to the disc pack.

- A. Clutch
- B. 3/2 Control Valve
- C. Fixed Displacement Pump
- D. Filter
- E1 and E2. Throttle Valve
- F. 2/2 Control Valve
- G. Pressure Limiting Valve
- H. Oil Reservoir
- I. Rotary Connection

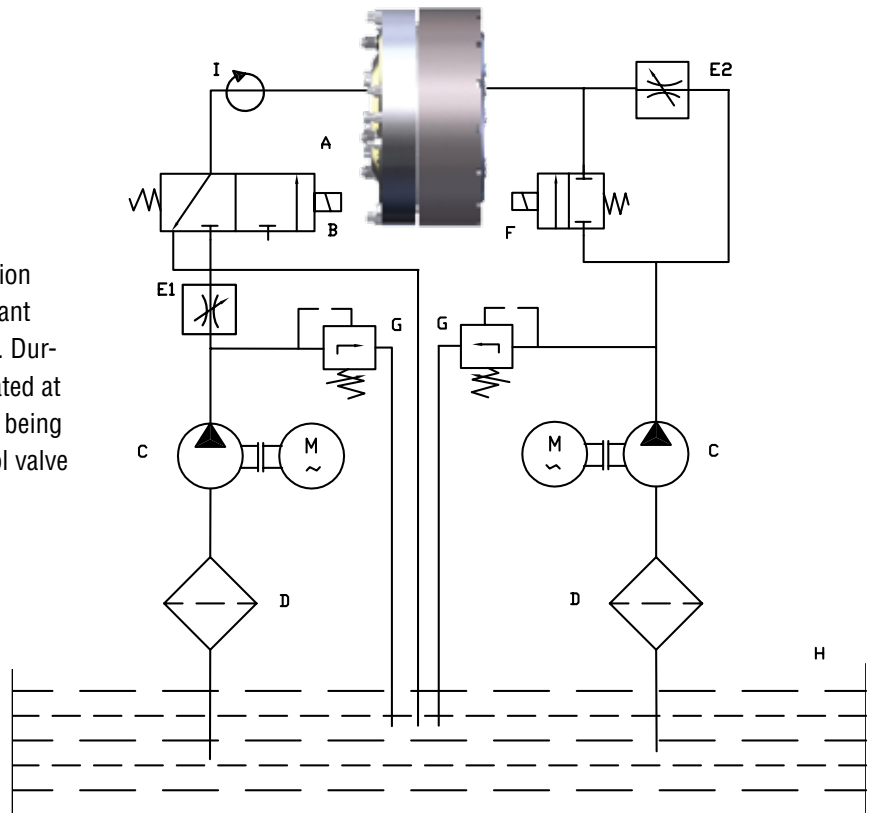

## Z-Drive Applications for Main Propulsion

Ports worldwide are requiring Tugs and Escort Vessels to handle larger ships within smaller, less maneuverable areas.

Logan CH Series clutches are ideal for stern drive tugs and work boats that require high torque transmission from a multiple disc wet or dry clutch - within a small envelope.

Dependability, reliability, ease of operation and maintenance are what make the Logan CH Series clutch an ideal choice for maritime propulsion.



**View of typical escort tug equipped with Z-drive propulsion, enabling more maneuverability in congested shipping ports**

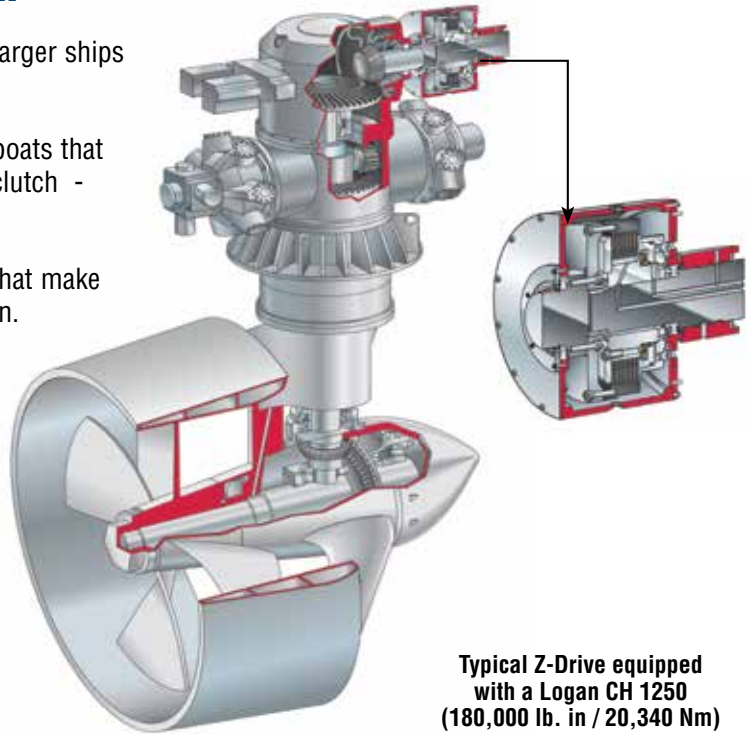

**Typical Z-Drive equipped with a Logan CH 1250 (180,000 lb. in / 20,340 Nm) @ 150 psi. / 12.2 bar**

## CH Clutches for Draw Works on Marine Oil Drilling Platforms

Logan CH clutches are used in all types of land and marine based draw works gearboxes for precise engagement and maximum torque transfer.



**View of the Deepwater Enterprise Drilling rig, equipped with (3) Logan CH clutches in its drawworks, capable of drilling up to 30,000 ft., in 8,500 ft. of water.**

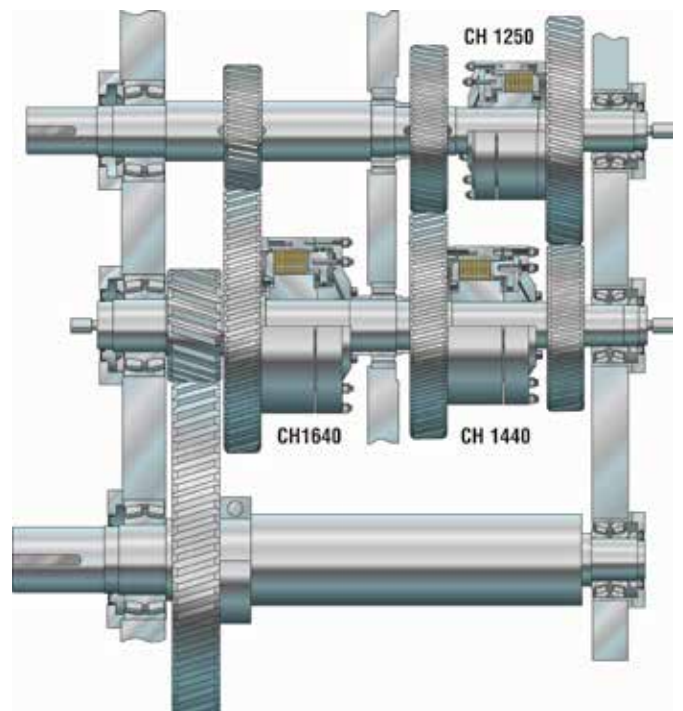

**A cut away view of a typical 5,000 HP Continental Emsco, 3-speed Electrohoist V drawworks, which uses Logan CH 1250, CH 1440, and CH 1640 air actuated clutches – all operating at 150 psi. / 10.2 bar**





## Marine Towing Winches



CH 1440 Clutch (270,000 lb. in. / 1,800 RPM)

### CH Clutches for Escort and Ship Assist Vessels

Logan CH Series clutches are specified on a variety of deck and hawser style winches (single and multi-speed), which are utilized during harbor and off-shore escort activity. Clutch-brake combinations assist with line tension control during render-recover mode in dynamic, open sea conditions.

## Clutches for Workboat Mooring Winches

- Torque ratings from 49,000 lb-in (5532 Nm) to 1,280,000 lb-in (144,000 Nm).
- Standard operating speeds from 1 to 2,200 RPM.
- Modified standards to meet specific design requirements.



CH clutch mounts between motor and winch



CH 1050 (140,000 lb. in. / 15,750 Nm)

#### FEATURES:

- High torque, small envelope
- Fluid or air actuated
- Wet or dry operation
- Smooth engagement

#### ADVANTAGES:

- American Bureau of Shipping (ABS) type approval. Other classification society certifications also available
- Smooth engagement – quick release
- Long wearing components



## Main Propulsion for High Speed, Medium and Heavy Duty Gear Drives

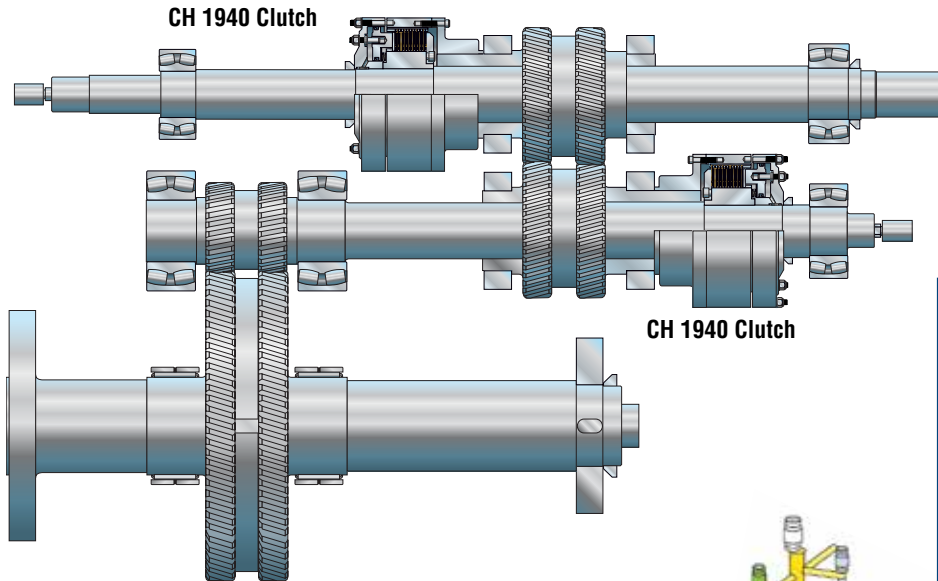

Logan CH Series clutches provide a wide range of power options. From main propulsion drive systems in workboats, tugs and cargo ships to ferries and transport vessels.



CH clutches for inland and ocean going vessels

Logan Sales, Engineering and Customer service personnel are available to answer inquiries regarding your specific CH Clutch design requirements.

Contact Logan today for more details.

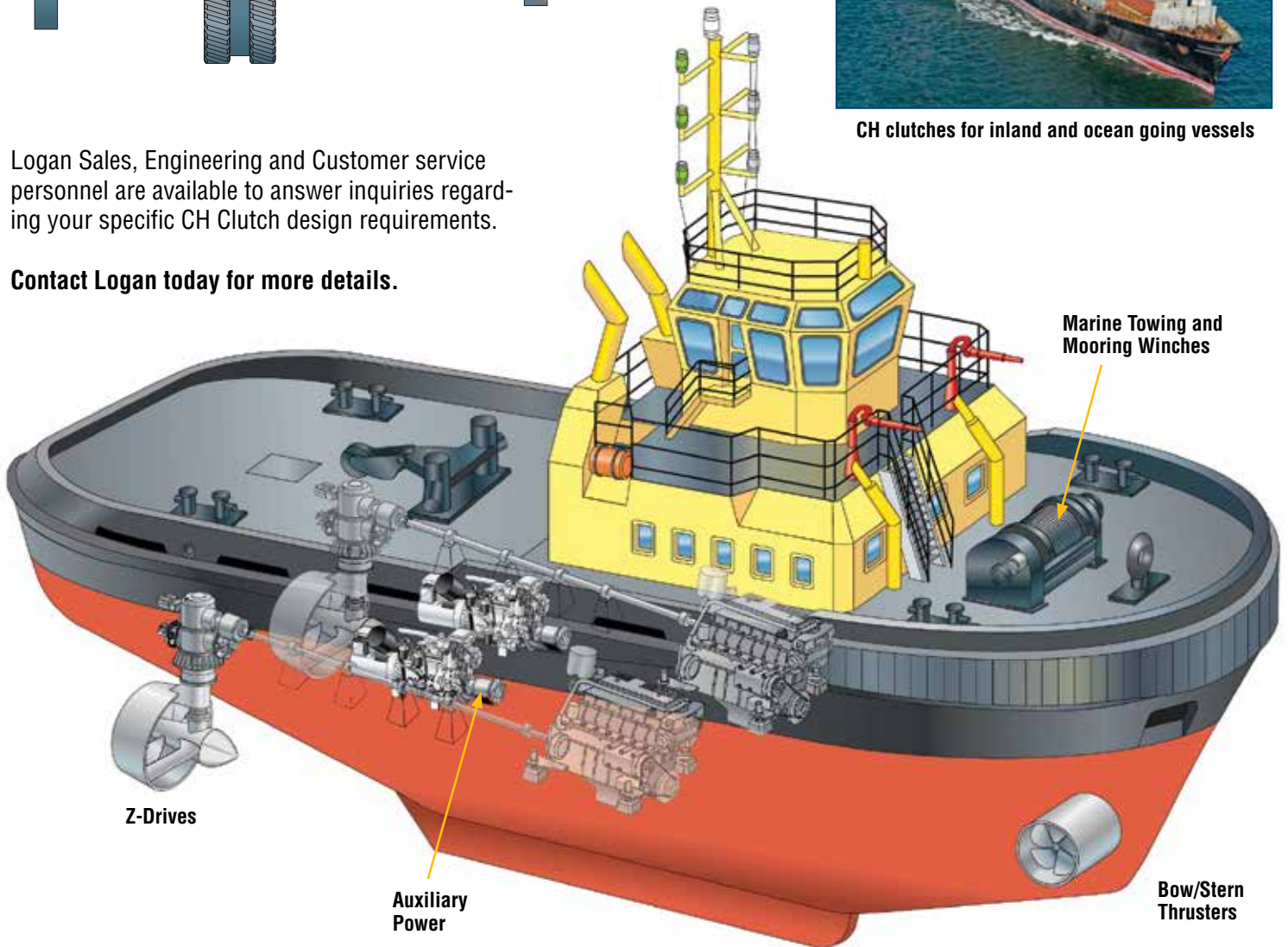

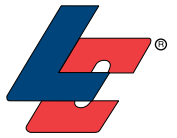

# Hybrid Tug Engine Room View

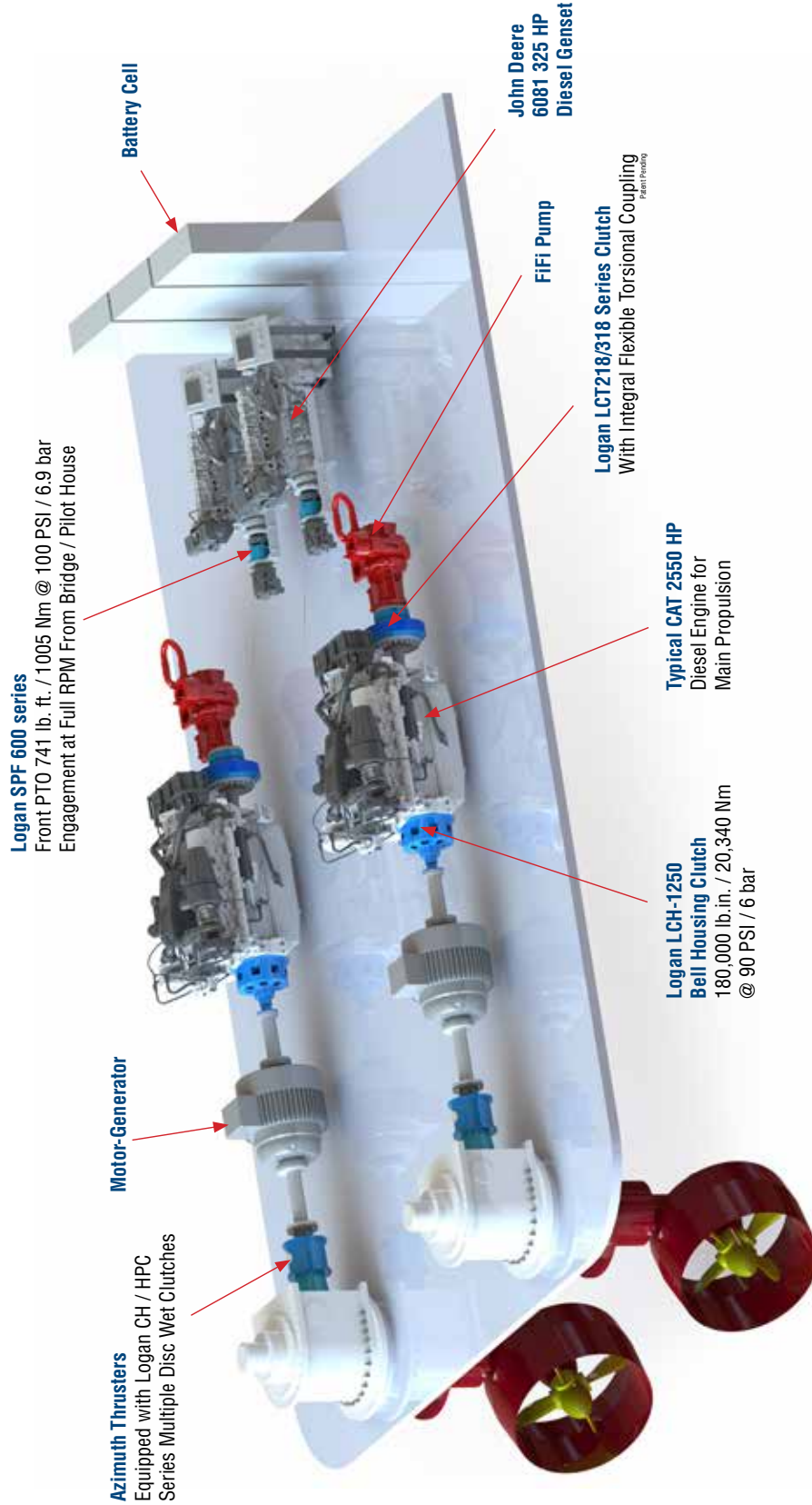



## New! Logan Bell Housing PTO Clutches

- Self Adjusting Disc Pack – Minimizes Slippage.
- Eliminates Mechanical Linkages, Hand Levers, and Yokes.
- Air or Fluid Actuated - (air is ideal for cold start applications).
- Fast Engagement - Quick Release.
- Remote Activation.
- Modified Standards Available.

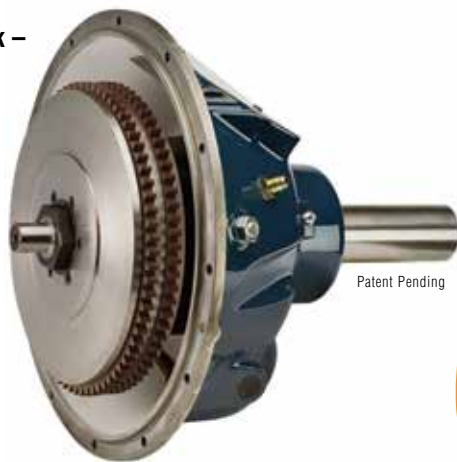

Logan Double Disc Bell Housing PTO

Patent Pending

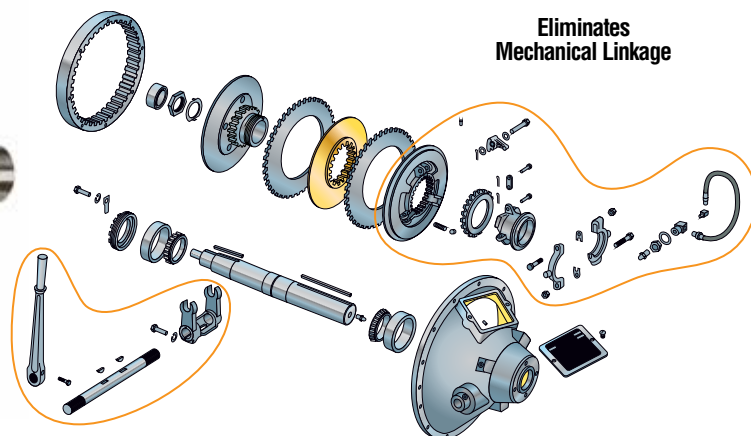

## New! Logan Front Mount PTO Clutches

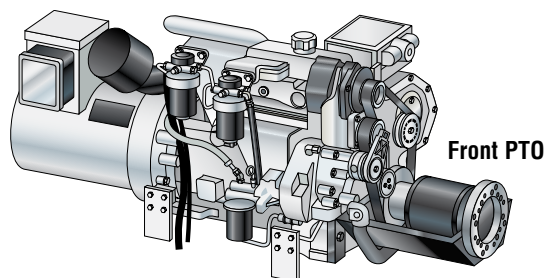

Gensets - Front PTO's

- Air / Fluid actuated, compact design is suitable for workboats, fishing boats and pleasure craft.
- Aids in reduction of emissions, fuel costs and wear and tear on auxiliary attachments.
- Directly connects to a pump drive, which powers: winches, bow and stern thrusters, reels, hoists and more.



View of front PTO for John Deere 4045T diesel engine

## Logan SAE PTO Clutches

Logan PTO Series Clutches are designed to mount between the power take-off of an engine, multi-station pump drive, hydraulic motor or pump. OEM and Aftermarket designers can take advantage of energy savings and component longevity by utilizing Logan PTO's to drive Auxiliary attachments only when required.

### PTO Applications:

- Single and Multi-station Pumps
- Mobile or Stationary Auxiliary Drives
- Connect-Disconnect Direct Drives
- Municipal Fire Trucks
- Air Rescue Fire Fighting Vehicles
- Marine Fishing Boats/Work Boats/Winches



SAE B to B, C to C and D to D Modified standards available.



3 Pad Pump Drive

Logan PTO

Fixed Displacement Pump

 **Logan Clutch Corporation**<sup>®</sup>  
 manufacturers of clutches and brake products  
 28855 Ranney Parkway • CLEVELAND, OH 44145  
 TEL: 440.808.4258 • FAX: 440.808.0003 • 800.5.CLUTCH or 800.525.8824 • sales@loganclutch.com  
[www.loganclutch.com](http://www.loganclutch.com)



Rev.12.2014

Copyright Logan Clutch Corporation, 2014. All Rights Reserved.