

MEDIUM AND HEAVY DUTY BRAKE DISCS

The e brake di c were de igned to go with our die ca t brake caliper . They are uitable for both fluid applied and pring applied brake . All di c are ventilated and can be u ed for medium to heavy-duty application . Normally they are ca t in ductile iron, however, other material are available to u it cu tomer requirement .

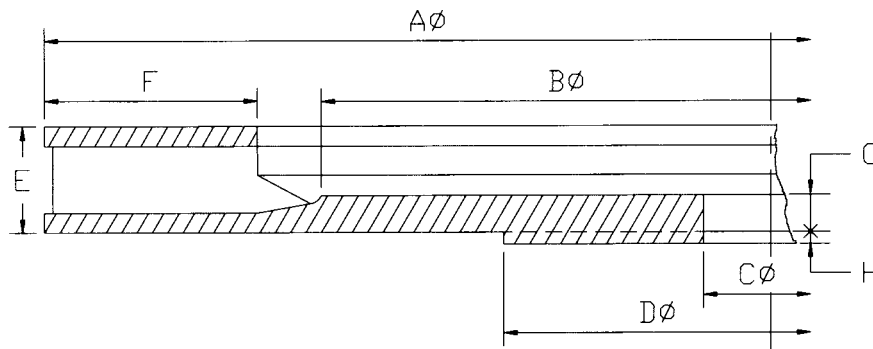

3/4 x 2 Serie for Caliper 5019	A Diameter		B Max. Diameter		C Min. Diameter		D Max. Diameter		Max. RPM	Weight*		Act. Rad		
	inch	mm	inch	mm	inch	mm	inch	mm		lbs.	kg.	ft.	m	
	9	229	5	127	2	51	3.75	95	6150	8	4	0.29	0.09	
Dim. E=0.750 in 19mm	12	305	8	203	2	51	5	127	4550	15	7	0.42	0.13	
Dim. F=2.000 in 51mm	15	381	11	279	2	51	6	152	3600	21	10	0.54	0.17	
Dim. G=0.375 in 10mm	18	457	14	356	2	51	7	178	3000	29	13	0.67	0.20	
Dim. H=0.125 in 3mm	20	508	16	406	2	51	8	203	2680	36	16	0.75	0.23	
1-1/4 x 2-1/2 Serie for Caliper 5020	12	305	4.5	114	2.0	51	3.75	95	4600	19	9	0.39	0.12	
	15	381	7.5	191	2.5	64	5	127	3650	27	12	0.52	0.15	
	18	457	10.5	267	3.0	76	6	152	3000	37	17	0.65	0.19	
	Dim. E=1.250 in 32mm	21	533	13.5	343	3.5	89	9	229	2550	50	23	0.77	0.23
	Dim. F=2.750 in 70mm	24	610	16.75	425	4.0	102	8	203	2250	64	29	0.89	0.27
	Dim. G=0.625 in 16mm	27	686	19.5	495	4.0	102	12	305	1980	79	36	1.02	0.31
Dim. H=0.250 in 6mm	30	762	22.75	578	4.5	114	10	254	1780	99	45	1.14	0.34	
2 x 4 Serie for Calipers 5021, 5022, 5023 5024, 5027	18	457	7	178	3.25	83	7.75	197	3070	74	34	0.58	0.18	
	20	508	9	229	4	102	9.75	248	2750	86	39	0.67	0.20	
	25	635	14	356	3.5	89	9.75	248	2200	118	54	0.88	0.27	
	30	762	19	483	4.5	114	13	330	1800	165	75	1.08	0.33	
	Dim. E=2.00 in 51mm	35	889	24	610	5.5	140	13.75	349	1550	212	96	1.29	0.39
	Dim. F=4.25 in 108mm	40	1016	29	737	6	152	15	381	1350	263	119	1.50	0.46
	Dim. G=0.75 in 19mm	45	1143	34	864	8.25	210	15.75	400	1200	302	137	1.71	0.52
Dim. H=0.25 in 6mm	50	1270	39	991	10.25	260	19.5	495	1070	358	162	1.92	0.58	

*Weight may vary due to machining