

# BRAKE DISC DETAILS FOR HIGH ENERGY INPUT

The e brake di c were developed for medium to high energy input. The patented fin de ign offer the ultimate in heat tran fer and air flow. Thi di c will accompli h ta k not po ible with ordinary ventilated di c .

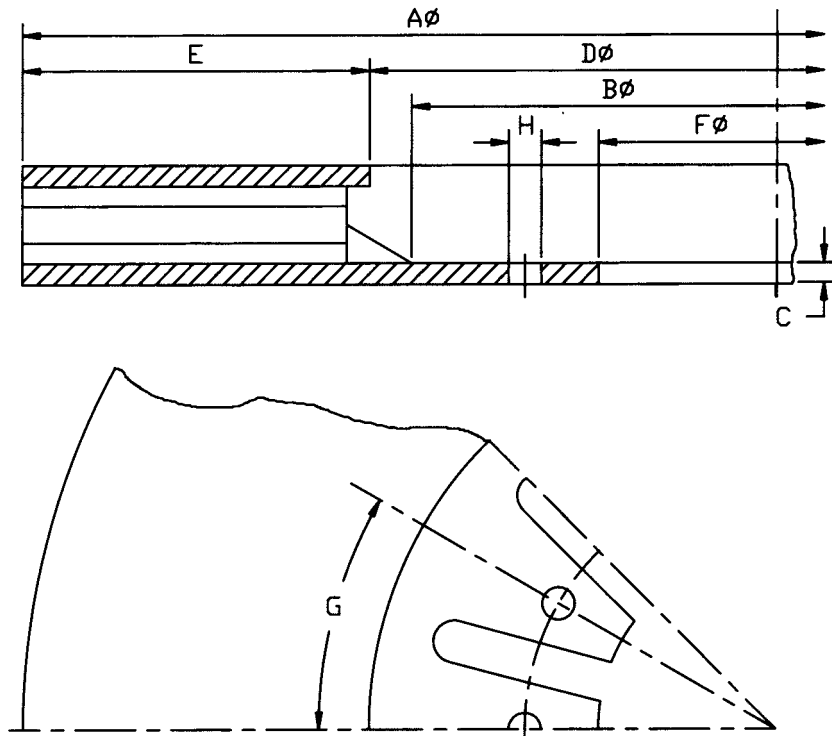

## 4 SERIES BRAKE DISCS

Caliper Number	5025, 5026				5028, 5040, 5054							
	4.00				4.00							
A	30.0	35.0	40.0	48.0	42.5	48.5	54.5	60.5	72.0	84.0	96.0	
B	14.0	18.0	23.0	31.0	18.5	23.5	29.5	35.5	46.0	58.0	70	
C	1.0	1.0	1.0	1.0	1.0	1.0	1.12	1.12	1.12	1.12	1.12	
D	16.0	21.0	26.0	34.0	21.5	27.5	33.5	39.5	50.0	62.0	74.0	
E Face	7.0	7.0	7.0	7.0	10.5	10.5	10.5	10.5	10.5	10.5	10.5	
F (Min.)	8.0	14.0	19.5	19.6	15.0	18.0	23.1	27.0	38.0	50.0	62.0	
F (Max.)	11.0	16.0	21.0	29.0	17.5	23.5	25.0	31.0	42.0	54.0	66.0	
G	30°	30°	20°	20°	30°	30°	20°	18°	15°	15°	15°	
H (to customers' requirements)	11/16	11/16	11/16	11/16	11/16	11/16	1-3/32	1-3/32	1-3/8	1-3/8	1-3/8	
WR <sup>2</sup> (lb. ft. <sup>2</sup> )	365	635	1010	1990	1160	2010	3010	4220	9170	16600	26900	
Acting Rad (ft.)	0.96	1.17	1.37	1.71	1.33	1.58	1.83	2.08	2.54	3.04	3.54	
Weight (lb.)	380	460	530	690	620	790	890	980	1450	1860	2240	
Max. Cont. HP	65	80	100	120	140	170	195	220	280	340	400	
Cont. HP 100 RPM	25	35	45	60	55	70	90	150	240	340	400	
Max. RPM	1800	1500	1300	1100	1300	1100	1000	900	700	600	500	
HP.-Sec. (Cont. Input)	33000	40000	47000	60000	54000	69000	78000	86000	128000	163000	200000	

Note: WR<sup>2</sup> and Weight may vary lightly from value given in the table.