

Reverse-Locking Clutches Models RL-35A thru RL-160A

Service & Installation Instructions

P-222-26-FC
Bulletin 4501



 **Formsprag**[®]
Clutch

An **Altra Industrial Motion** Company

Introduction

The RL Clutch is a sprag type no-back which permits transmission of driving torque from input to output shaft in both directions of rotation, but which restrains any feed-back torque of the driven load from rotating the output shaft in either direction.

⚠ WARNING Failure to follow these instructions may result in product damage, equipment damage, and serious or fatal injury to personnel.

Installation

Formsprag RL Reverse Locking Clutches are factory lubricated with Fiske Brothers low-temperature grease and are shipped ready to install. Remove the plastic plug from the outer race grease hole and place the RL clutch in the housing. Housing bore and clutch OD fits are tabulated below.

Note: Check to be sure the proper clutch member is aligned with the input before installing.

Install input and output shafts and keys and install ball bearings on each side of the RL clutch. See sketches on page 6. The bearings required to support the shafts to prevent radial and thrust loads from being applied to the RL clutch are also required to maintain alignment of the shafting. Use more than one bearing on each side if necessary to prevent deflection of the shafting due to external loading. (Bearings may not be needed with model RL-35 in light duty applications.) Check Catalog P-956 for overhauling loads and breakaway torques.

Note: Check to be sure the housing grease hole is in line with the grease hole in the RL clutch outer race.

RL clutches may be furnished for oil lubrication by special order. See instructions on page 3 for oil lubricated RL clutches.

Installing Oil Lubricated RL Clutches

Place the RL clutch in the housing. Follow instructions given above for installing the RL clutch, shafts and bearings. Install oil seals in the housing if necessary to prevent loss of oil from the RL clutch and from the housing. Provide a hole in the top of the housing in line with the hole in the RL clutch outer race. This hole may be used for supplying oil to the clutch. In addition, if oil seals are used, provide a hole in the housing at the one half full level. Use this for adding oil to the housing until the housing is one half and for periodic checking of the oil level. Also provide a drain at bottom of housing for draining and flushing. (See Maintenance.)

Add oil before operating the RL clutch. (See Lubrication.)

Shaft Fits

A clearance fit .001 to .003 inches loose is recommended. Do not use press fits. (See table of Dimensional Data below.)

O.D. Housing Fits

RL clutch outside diameters are machined to fit in housings of standard ball bearing housing bores. Refer to ball bearing manufacturers recommendations. If housing bores are not prepared to ball bearing dimensions, a line fit to .002 inches loose is recommended.

Key Fits

A clearance fit from .001 to .002 inches loose is recommended for shaft and housing keys.

Alignment

Angular alignment of end to end shafts connected to the RL clutch must be within .001 inches per inch of shaft length. Parallel alignment must be within .001 of an inch per inch of nominal shaft diameter. These figures are maximum for either shaft to shaft or shaft to housing bore measurements.

Lubrication

Model RL-35A

Factory lubricated for life with special lubricant. No further Lubrication is required.

Models RL-47A thru RL-160A

These RL clutches are furnished grease packed. (Oil lubricated models are furnished by special order only.)

Grease Lubrication

Packed full at factory with Lubriplate Low-Temp. grease, a product of Fiske Brothers Refining Company. Consult Formsprag Clutch if the operating temperature is less than 20°F. Also consult Formsprag Clutch for approval before using alternate greases.

Oil Lubrication

Temperature Range	Recommended Lubricant
+20°F to +150°F	Mobil DTE Heavy Medium
+20°F to -10°F	Mobil Gargoyle Arctic C Heavy
-10°F to -30°F	Mobil Arctic 155
-30°F or below	Consult Formsprag for silicone base lubricant developed specially for the RL clutch.

RL clutches should be 1/2 full of oil.

Important: Use Factory Recommended Lubricants only.

Models RL-47A thru RL-160A

Add grease every ninety (90) days. Under severe or dusty conditions or twenty-four hour daily operation, lubricate monthly. Insert grease fitting into grease hole in housing. Add grease until the old grease is purged from the RL clutch.

Oil Lubricated Models

Maintain oil level in RL clutch and housing one third to one half full. Check oil level weekly. Use factory recommended oils only. Add oil to RL clutch through hole provided at top of housing. Add oil to housing through hole provided at the one half full level.

Note: Oil will flow from clutch to housing or from housing to clutch. However, since clearances are small, flow will be slow. Adding oil to both clutch and housing will speed oil adding process.

Important: Every ninety (90) days, drain oil from clutch and housing and flush with mineral spirits. Operate the clutch for 5 to 10 minutes to break up and dissolve the oily residue which may have formed. After flushing, add oil to clutch and housing as above.

The RL clutch is available in several model sizes. The RL-35A is an economical, ball bearing, clutch specifically designed for hard operations, light duty machine tools, data processing equipment, instruments, etc. It is completely enclosed, self-contained, and permanently lubricated at the factory. The RL 35A is mounted through the external flange and pin holes in the included split shaft. Models RL-47A thru RL-160A are larger units applicable in an extensive torque capacity range. These models require lubrication.

Model RL-35A

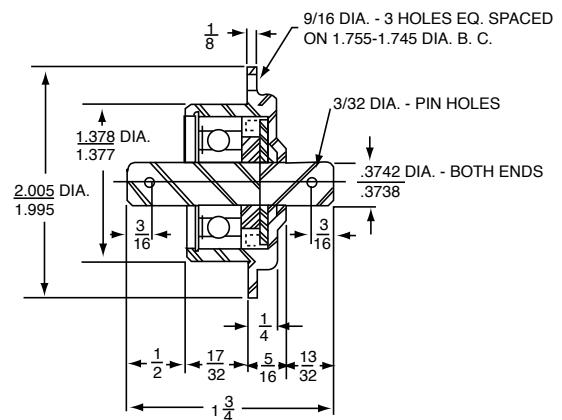

Model RL-47A Through RL-160A

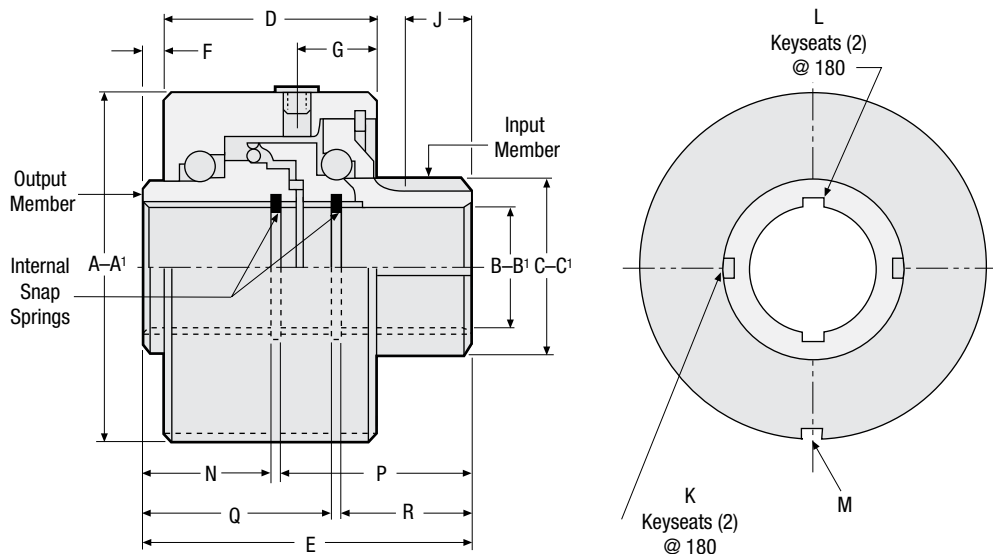

Dimensional Data

Model	A	B	C	±.010 D	±.010 E	K	M	L	±.010 J	±.020 F	±.010 G
RL-35A	Refer to drawing on page 4 for dimensions										
RL-47A/.500	1.8504	0.500	0.783	1-9/16	2-1/8	3/32X3/64	1/8X1/16	3/32X3/64	7/16	1/32	11/16
	1.8499	0.501	0.782								
RL-72A/1.000	2.8346	1.00	1.376	1-23/32	2-5/8	5/32X5/64	1/8X1/16	5/32X5/64	5/8	5/32	27/32
	2.8341	1.001	1.375								
RL-115A/1.500	4.5276	1.500	2.001	2-9/32	3-9/64	1/4X1/8	1/4X1/8	1/4X1/8	11/16	1/32	7/8
	4.5271	1.501	2.000								
RL-130A/2.000	5.1181	2.000	2.845	2-53/64	4-11/64	5/16X5/32	1/4X1/8	5/16X5/32	1-1/32	1/32	1
	5.1173	2.001	2.844								
RL-160A/2.500	6.2992	2.500	3.876	3-3/32	4-23/32	1/2X1/4	1/4X1/8	1/2X1/4	15/16	1/32	1
	6.2982	2.501	3.875								

Note: R-Snap rings to prevent key movement.

Attachment Dimensional Data

Model	A ¹ Housing Bore	B ¹ Shaft Dia.	C ¹ Bore Dia.	Engagement Lengths			
				N	P	Q	R
RL-47A/.500	1.8514	0.499	0.7833	25/32	1-3/16	1-5/32	13/16
	1.8520	0.498	0.7838				
RL-72A/1.000	2.8356	0.999	1.3763	1	1-15/32	1-15/32	1
	2.8362	0.998	1.3768				
RL-115A/1.500	4.5286	1.499	2.0013	1-3/16	1-25/32	1-25/32	1-3/16
	4.5294	1.498	2.0020				
RL-130A/2.000	5.1191	1.999	2.8453	1-5/8	2-3/8	2-3/8	1-5/8
	5.1201	1.998	2.8463				
RL-160A/2.500	6.3002	2.499	3.8763	1-7/8	2-11/16	2-11/16	1-7/8
	6.3012	2.498	3.8775				

Engineering Data

Model	Rated Capacity Lb. In.	Drag After Break-in Lb. In. (1)	Max. Operating Speed R.P.M. (2)	Weight Lb.
RL-35A/.375	96	1.0	1800	0.33
RL-47A/.500	300	1.0	1800	0.95
RL-72A/1.000	2,400	2.0	1800	2.5
RL-115A/1.500	8,500	5.0	1200	8.9
RL-130A/2.000	18,000	10.0	1200	13.3
RL-160A/2.500	26,500	20.0	900	22.9

(1) Break-in is equivalent to 24 hours of operation under ordinary circumstances.

(2) Maximum driving speed permissible with grease pack if inertia torque as determined by selection procedure does not exceed rated torque.

Typical Installations

RL Reverse Locking Clutch

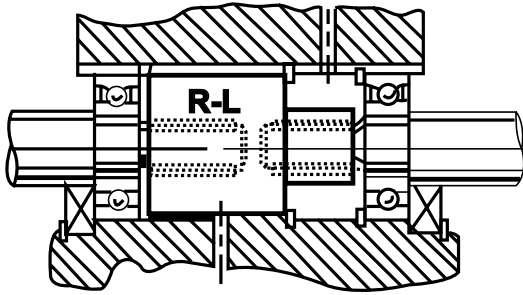

Fixed Housing – Grease Lubrication. (Grease purge hole required with shielded bearings.) If seals are used, install with lip outward. (All RL Models; RL-72, 115, 125 and 160 configuration shown.)

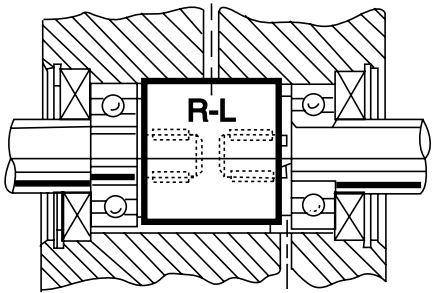

Fixed Housing – Oil Lubrication. Oil hole required at half full level and drain hole at bottom. Install seals with lips inward. (All RL Models; 47 configuration shown.)

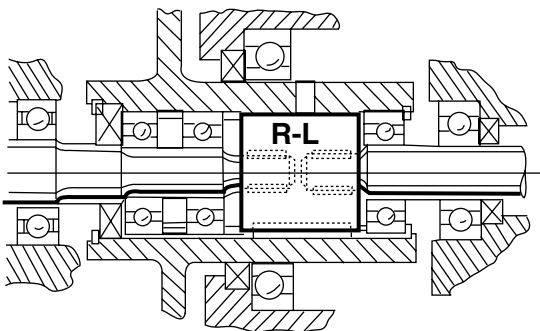

“Live Outer Race” Mounting Arrangement.
(All RL Models; 47 configuration shown.)

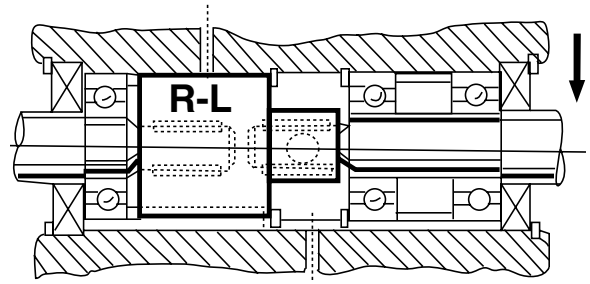

“Live Outer Race” Mounting Arrangement. (All RL Models; 47 configuration shown.)

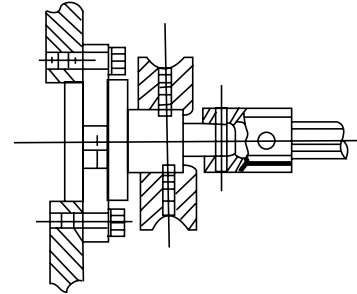

Fixed Housing – “Overhung load” supported by two bearings. (All RL Models; RL-72, 115, 125 and 160 configurations shown.)

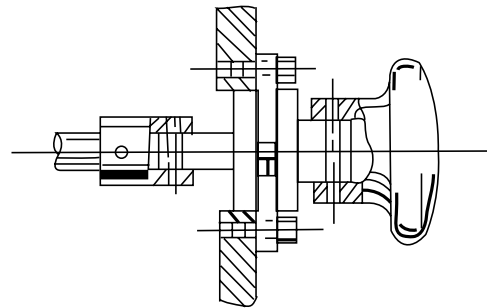

“Coaxial Arrangement” Flanged outer race fixed to stationary support, pulley fixed to control member with set screws and output shaft coupled to socket member with “Rollpins”. (RL-35)

Flanged outer race fixed to stationary support, hand knob fixed to control member with “Rollpin” and output shaft coupled to socket member with “Rollpins”. (RL-35)

Warranty

Formsprag LLC warrants that it will repair or replace (whichever in its sole discretion it deems advisable) any product it manufactured and sold which proves to be defective in material or workmanship within a period of one (1) year from date of original purchase for consumer, commercial or industrial use. This warranty extends only to the original purchaser and is not transferable or assignable without Formsprag LLC's prior consent.

This warranty covers normal use and does not cover damage or defect which results from alterations, accident, neglect, disassembly, or improper installation, operation, or maintenance.

Formsprag LLC's obligation under this warranty is limited to the repair or replacement of the defective product. In no event shall Formsprag LLC be liable for consequential, indirect or incidental damages of any kind incurred by reason of manufacture, sale or use of any defective product. Formsprag LLC neither assumes nor authorizes any other person to give any other warranty or to assume any other obligation or liability on its behalf.



www.formsprag.com

23601 Hoover Road
Warren, MI 48089
586-758-5000
Fax: 586-758-5204

An **Altra Industrial Motion** Company

