

# General Purpose Clutches

## FSO/HPI

### Overrunning, Indexing, Backstopping Ball Bearing Supported, Sprag Clutches



All models contain **PCE** sprags with Formchrome® and Formsprag “Free-action” retainers except models FSO 550 & FSO 650. Standard clutches and all C/T clutches are oil lubricated. Grease lubrication is available for applications where maintenance is inadequate, or where higher inner race overrunning speeds are required. These clutches mount on a through-shaft, with the inner race driven by a key. The ground O.D. of the outer race is designed as a pilot or mounting surface for attaching parts and is concentric with the bore. Tapped holes are provided in each end of the outer race for securing these parts to the clutches. Refer to Bore Sizes/Shaft Tolerances chart for mounting data, page 128.

For vertical mounting, contact Application Engineering.

### Model FSO

General purpose, ball-bearing clutches suitable for overrunning, backstopping and light to medium-duty indexing applications. They are oil lubricated and equipped with lip type seals. Grease is available. Increased speeds are possible with steel labyrinth seals.

### C/T Sprag Models (FSO Only)

C/T sprag clutches are ideal for applications with high speed outer race overrunning and low speed driving. Available with oil lubrication only.

### Model HPI

Especially designed for **medium to heavy-duty** indexing applications, or applications in excess of 150 strokes/min. to provide the maximum in dependable, uniform, long life performance except models FSO 550 & FSO 650. They are oil lubricated and equipped with lip type seals. Grease is available.

### Oil Lubricated Clutches

FSO-300 through 700 clutches are shipped from the factory with Mobil DTE Heavy Medium oil.

HPI-300 through 700 clutches are shipped from the factory with Mobil DTE Light oil.

### Grease Lubricated Clutches

FSO-300 through 700 clutches are shipped from the factory packed with Fiske Brothers Lubriplate Low-Temp grease.

HPI-300 through 700 clutches are shipped from the factory with Fiske Brothers Lubriplate Low-Temp grease.

OSHA cover kits are available for Models FSO & HPI-400 through 700, see page 125 for details.

For further information, write for Installation and Maintenance Bulletin No. 2219, P-222-10 for the FSO series and No. 2213, P-222-6 for the HPI series.

### Typical Mounting Arrangement

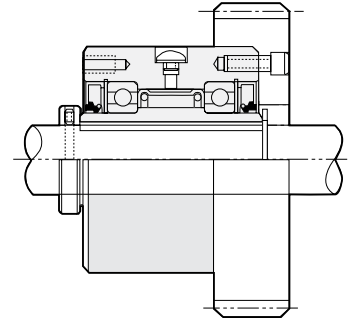

The Model FSO clutches must be axially restrained, see accessories page 122 for set collars, restraint keys and OSHA covers, etc. All fasteners are recommended to be grade 8 bolts.

### Specifications

Size	Torque Capacity lb.ft. (Nm)	Maximum RPM								Resistance after run-in lb.ft. (Nm)	Lubrication		Shipping Weight lb. (kg)
		Standard Models				C/T Sprag Models					Oil or Grease	Oil only	
		Overrunning Speed				Overrunning Speed							
		Oil and Grease Lip Seals		Labyrinth Grease Seals		Overrunning Speed		Max. drive	Sprag lift-off		FSO oz (ml)	HPI oz (ml)	
		Inner Race	Outer Race	Inner Race	Outer Race	Inner Race	Outer Race						
300	275 (374)	3,000	900	3,600	900	3,000	6,000	1,100	1,300	.13 (.18)	.25 (7.0)	.50 (14.0)	3.5 (1.6)
400	300 (408)	2,800	850	3,600	850	2,800	5,000	1,100	1,300	.20 (.27)	.33 (9.9)	.67 (19.8)	6 (2.7)
500	1,175 (1598)	2,500	800	3,000	800	2,500	4,000	1,000	1,200	.23 (.31)	.75 (22.0)	1.25 (35.0)	10.5 (4.8)
550	1,885 (2564)	1,175	800	—	—	—	—	—	—	.35 (.47)	1.75 (52.0)	—	12 (5.4)
600	2,250 (3060)	2,200	750	2,400	750	2,200	3,600	1,000	1,200	.46 (.62)	1.75 (52.0)	3.00 (84.0)	19 (8.6)
650	2,375 (3230)	900	600	—	—	—	—	—	—	.80 (1.08)	6.00 (168.0)	—	24 (10.8)
700	5,000 (6800)	1,600	450	2,000	450	1,600	2,500	800	1,000	1.15 (1.56)	6.00 (168.0)	10.00 (280.0)	42 (19)

**Note:** Check key and shaft stress before making final clutch selection since this may determine the maximum allowable drive torque capacity. Shaft keys are not provided with the clutches on sizes 300 through 700.

FSO OSHA cover kits are designed for shaft end mounted FSO or HPI clutches and available from Formsprag from size 400 through 1027. These cover kits provide not only the stationary cover enclosure required by OSHA, but provide additional protection for the clutch from abrasive environments as well.

**Note:** OSHA requires that a stationary guard must enclose clutches with rotating projecting parts and operating seven (7) feet or less above the floor.

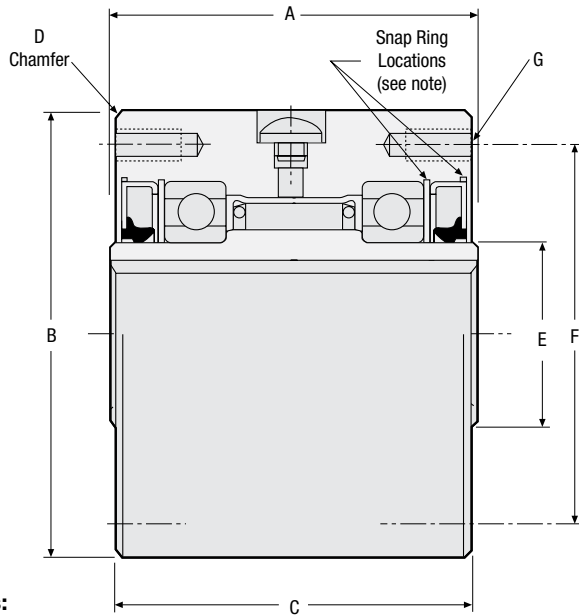

**Notes:**

Angle — oil hole to mounting bolt hole

Model 300, 400, 500= 45°

600 = 15°

700 = 0° or 30° (offset from center of outer race)

Snap ring is located on the outboard side of the oil seal on Models 400, 600 and 700. On Models 300 and 500, snap ring is inboard of the oil seal.

**Dimensions** inches (mm)

Size	A	B	C	D	E	F	G		
							Number	Thread	Depth
300	2.50 (63.50)	3.000/2.998 (76.20/76.15)	2.38 (60.45)	.06 x 45° (1.58 x 45°)	1.12 (28.58)	2.625 (66.67)	4 @ 90°	.250-28	.50 (12.70)
	400	2.75 (69.85)	3.500/3.498 (88.90/88.85)	2.69 (68.26)	.06 x 45° (1.58 x 45°)	1.19 (30.15)			2.875 (73.02)
500		3.50 (88.90)	4.250/4.248 (107.95/107.90)	3.38 (85.72)	.06 x 45° (1.58 x 45°)	1.77 (45.0)	3.625 (92.07)	4 @ 90°	.312-24
	550	3.25 (82.55)	4.750/4.748 (120.65/120.60)	3.125 (79.38)	0.08	2.75 (69.85)	4.25 (107.95)		
600		3.75 (95.25)	5.375/5.373 (136.53/136.47)	3.63 (92.07)	.06 x 45° (1.58 x 45°)	2.50 (63.50)	4.750 (120.65)	6 @ 60°	.312-24
	650	3.50 (88.90)	6.500/6.498 (165.1/165.05)	3.375 (85.72)	0.09	3.187 (80.94)	5.75 (146.05)		
700		5.00 (127.00)	7.125/7.123 (180.97/180.92)	4.88 (123.82)	.06 x 45° (1.58 x 45°)	3.56 (90.42)	6.250 (158.75)	8†	.375-24

**Notes:**

† Six holes equally spaced at 60° plus two extra holes at 180°. Six hardened mounting screws are adequate for torque loads up to 3000 lb.ft. (4068 Nm). Use eight hardened mounting screws for torque loads above these values.

‡ The "E" dimension is larger for this bore size.

**Bore sizes and keyseats\*\*\*\***

inches (mm)

Size	Bore Size	Keyseat	Bore Range	
			Min.	Max.
300	.500 (12.70)	1/8 x 1/16 (3.18 x 1.57)	.500 (12.70)	.750 (19.05)
	.625 (15.87)	3/16 x 3/32 (4.75 x 2.36)		
	15mm	5 x 2.3mm***		
	.750 (19.05)	3/16 x 3/32 (4.75 x 2.36)		
400	.500 (12.70)	1/8 x 1/16 (3.18 x 1.57)	.437 (11.10)	.875 (22.22)
	.625 (15.87)	3/16 x 3/32 (4.75 x 2.36)		
	18 mm	6 x 2.8mm***		
	.750 (19.05)	3/16 x 3/32 (4.75 x 2.36)		
	.875 (22.22)	3/16 x 1/16 (4.75 x 1.57)		
	.875 (22.22)	3/16 x 3/32 (4.75 x 2.36)		
500	1.000 (25.40)	1/4 x 1/8 (6.35 x 3.18)	.750 (19.05)	1.312 (33.32)
	1.125 (28.57)	1/4 x 1/8 (6.35 x 3.18)		
	30mm	10 x 3.3mm***		
	1.250 (31.75)	1/4 x 1/8 (6.35 x 3.18)		
	1.312 (33.32)	1/4 x 3/32 (6.35 x 2.29)		
	1.250 (31.75)	1/4 x 1/8 (6.35 x 3.18)		
	1.312 (33.32)	3/8 x 3/16 (9.52 x 4.75)		
	1.5000 (38.10)	3/8 x 3/16 (9.52 x 4.75)		
600	1.625 (41.27)	3/8 x 1/8 (9.52 x 3.18)	.937 (23.80)	2.250* (57.15)
	1.250 (31.75)	1/4 x 1/8 (6.35 x 3.18)		
	1.375 (34.92)	3/8 x 3/16 (9.52 x 4.75)		
	1.5000 (38.10)	3/8 x 3/16 (9.52 x 4.75)		
	40mm	12 x 3.3mm***		
	1.625 (41.27)	3/8 x 3/16 (9.52 x 4.75)		
	1.750 (44.45)	3/8 x 3/16 (9.52 x 4.75)		
	45mm	14 x 3.8mm***		
	50mm	14 x 3.8mm***		
	2.000 (50.80)	3/8 x 1/8 (9.52 x 3.18)		
650	1.937 (49.20)	1/2 x 1/4 (12.70 x 6.35)	1.69 (42.85)	2.500 (63.5)
	2.000 (50.80)	1/2 x 1/4 (12.70 x 6.35)		
	2.250 (57.15)	1/2 x 1/4 (12.70 x 6.35)		
	2.437 (61.90)	5/8 x 1/8 (15.87 x 3.18)		
	2.500 (63.50)	5/8 x 1/8 (15.87 x 3.18)		
	1.937 (49.20)	1/2 x 1/4 (12.70 x 6.35)		
	50mm	14 x 3.8mm		
	2.000 (50.80)	1/2 x 1/4 (12.70 x 6.35)		
	2.250 (57.15)	1/2 x 1/4 (12.70 x 6.35)		
	60mm	18 x 4.4mm***		
	2.437 (61.90)	5/8 x 5/16 (15.87 x 7.93)		
	2.500 (63.50)	5/8 x 5/16 (15.87 x 7.93)		
65mm	18 x 4.4mm***			
2.750 (69.85)	5/8 x 7/32 (15.87 x 5.53)			
70mm	20 x 4.9mm***			
2.937 (74.60)	5/8 x 1/8 (15.87 x 3.18)			
75mm	20 x 4.9mm***			
80mm	22 x 5.4mm***			

\* 1/2 x 1/8 keyway. \*\* 3/4 x 1/4 keyway.

\*\*\* Contact Formsprag for keyseat information.

\*\*\*\* For Bore Sizes/Shaft Tolerances, see page 128.

† The "E" dimension is larger for this bore size.