

# General Purpose Overrunning Clutches

F50 300 thru 700 • F50 750 thru 1027

FS 750 thru 1027

Service & Installation Instructions

P-222-10-FC  
Bulletin 2219

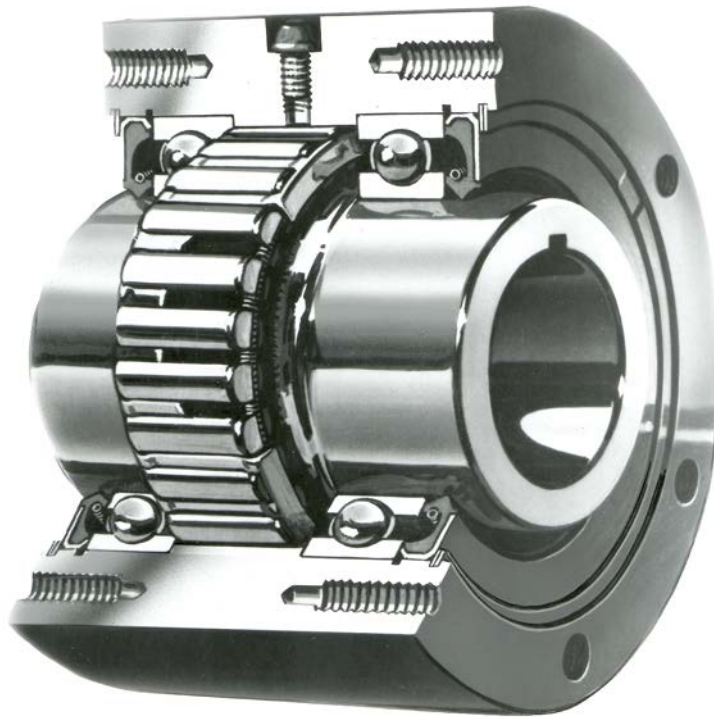

 **Formsprag Clutch**<sup>®</sup>  
*Altra Industrial Motion*

## Introduction

FS and FSO models are general purpose ball bearing clutches suitable for overrunning, backstopping and light duty indexing applications. They feature Formchrome®, PCE™ sprags and Formsprag's exclusive "Free-Action" Retainer for longer life and instant engagement.

- Formsprag ball bearing clutches mount on a through-shaft with the inner race driven by a key.
- The O.D. of the outer race is designed as a mounting surface or pilot for attaching the driven member.
- The O.D. of the outer race is ground to control concentricity with the bore and provide for proper alignment during installation.

**⚠ WARNING** Failure to follow these instructions may result in product damage, equipment damage, and serious or fatal injury to personnel.

## Pre-installation Check

Before installing, check:

### 1. Shaft to Bore fit:

Clutch Bore	Shaft Fit Guide*
0 to 2 inches dia.	line fit to .002 inches loose
2 to 4 inches dia.	line fit to .0025 inches loose
4 to 7 inches dia.	line fit to .003 inches loose

\*If a press fit is necessary under special circumstances, do not exceed .001 in. tight.

In some cases, builders of equipment in which a Formsprag clutch is used specify other shaft fit limits than those listed. In this event, direct questions concerning fit limits to the equipment manufacturer.

### 2. Key and Keyseat

**Hardness:** Use a hardened key, from 30 to 40 Rockwell "C" scale. Use materials AISI 1141, 1045 or 4130.

### Overrunning & Backstopping

**Fit:** Break edges of the key before installing to prevent any bearing at these points. Install with a push fit. Be sure the key seats squarely. Do not use a force fit.

**Length:** The key must be equal to the length of the inner race for proper engagement.

## Indexing

**Fit:** Fit the key up to .001 inch interference on WIDTH dimension to prevent loosening in indexing service. Do not exceed .001 inch tight.

### 3. Rotation

Check the clutch for the proper rotation in each application. Turn the inner race to check overrunning direction.

## Installation

1. If this FSO clutch is being used as part of a HSB assembly (High Speed Backstop, which is finned aluminum housing, mounted to the clutch for added speed capability and heat dissipation), please refer to the HSB Installation and Maintenance bulletin No, 2214 for complete mounting instructions. This bulletin is available from our Website [www.formsprag.com](http://www.formsprag.com) or contact Formsprag Clutch at 1-800-927-3262.

2. Mount the clutch and key on the shaft.

**Note:** Oil lubricated clutches should be mounted on horizontal shafts only. For vertical shaft mountings of oil lubricated clutches contact Formsprag Clutch.

3. Apply pressure to end face of the clutch inner race only.

Application of pressure to the outer race could preload the bearings excessively. For oil lubricated clutches, to simplify mounting, if a .001" interference fit is required, (this is the tightest allowable) immerse the clutch in hot, clean oil (not to exceed 200°F/93°C) for ten to fifteen minutes before mounting.

4. Secure the clutch in position on the shaft.

Use a lock washer and nut, a flat washer fastened to the shaft end with a screw, snap rings, collars, etc. to keep the clutch in position on the shaft.

5. Mount attaching parts to the clutch outer race as required by the application.

1. All fasteners are recommended to be grade 8 bolts.

If a torque arm is to be mounted to the clutch, allow .25 inch to .50 inch clearance between stops and torque arm.

Tapped mounting holes are provided in each end of the outer race. Center the gear, pulley or sheave on the outer race. Avoid excessive over-hung loads.

Check with Formsprag Clutch if the clutch must support large side loads during overrunning cycle of operation.

6. All Formsprag clutches are lubricated before leaving the factory. However, check the following Lubricant table for the proper lubricant and fill level for each type application and ambient operating temperature range. Change the lubricant or add oil to proper level, if required.
7. Check for proper installation by overrunning (free-wheeling) the clutch by hand.

## Lubrication

Proper lubrication and lubricant maintenance are the most important maintenance factors for long, effective, trouble-free clutch operation. Read the following instructions and follow them carefully for maximum performance and utilization of Formsprag overrunning clutches. **Always recheck oil level in clutch after installation and before start up.**

## Oil Lubrication

Use oils selected from the following table according to the application and ambient temperature existing at the clutch.

**Note:** FSO-300 thru 700 and FS-750 thru 1027 clutches are shipped from Formsprag half full of Mobil DTE Heavy Medium oil.

For applications where the ambient temperature exceeds +150°F (+65°C) consult Formsprag Clutch.

**⚠CAUTION** Do not use lubricants of the EP type (extreme pressure characteristics) or those containing slippery additives. For additional lube information, see Brochure #A-4032.

Temperature Range	Recommended Oil Lubricant
+20 to +150°F (-7°C to +65°C) (Maximum permissible ambient temperature)	Mobil DTE Heavy Medium Any Automatic Transmission Fluid (high grade only) Texaco Regal R&O 68 Shell Turbo Oil 68 Gulf Harmony 68 Amoco Industrial Oil 68 Exxon Teresstic Oil 68 Sunoco Sunvis 931 Lubriplate SFGO Ultra-22 oil (Food grade)
-10°F to +20°F (-23°C to -7°C)	Chevron Oil 46 Chevron GST Oil 931 Mobil Gargoyle Arctic C Heavy Texaco Regal R&O Oil 46 Sunoco Sunvis 921 Any Automatic Transmission Fluid (ATF) Lubriplate SFGO Ultra-22 oil (Food grade)
-40°F to +150°F (-40°C to +65°C) (Maximum permissible ambient temperature)	Mobil Jet Oil 2 Shell Turbine Oil 500 Exxon Turbo Oil 2389 Standard Esso Turbo Oil 2389 Military Oils MIL-PRF-7808 or MIL-PRF-23699 Lubriplate SFGO Ultra-22 oil (Food grade)

**Important:** Do not mix the oils, they are not compatible. When switching from one brand to another, drain old oil and flush clutch with mineral spirits. Do not use carbon tetrachloride before adding new oil.

**⚠WARNING** The use of lubricants in clutch assemblies, other than those shown, can result in improper sprag engagement. Improper sprag engagement may cause personal injury or property damage.

**Formsprag Clutch is not responsible for any changes made by the manufacturers in their lubricants.**

**The use of any lubricants, other than those listed in this manual, will automatically void any warranty.**

## Oil Lubrication Maintenance

1. Check the oil level once a month or every 160 hours of operation, whichever occurs first. For indexing applications and indexing in excess of 150 strokes a minute, oiling may be required at shorter intervals and use Models HPI. See Bulletin 2213.

2. Add oil if necessary to maintain the proper fluid level.

Overrunning, Backstopping – 1/2 full

Indexing – 7/8 full

3. To assure continued efficiency of operation, flush clutch every 6 months with mineral spirits. **Do not use carbon tetrachloride.**

**Important:** Under severe operating conditions, such as heavy dust or twenty-four hours per day operation, flushing may be required at shorter intervals.

Flushing will remove waxes and gums formed by vaporization of the oil and assure continued efficiency of operation. See "Flushing Procedure" section.

4. Flush with mineral spirits and relubricate before use if clutch has been out of service or in storage for six months or more. Use recommended oils only.

In cases of dirty or abrasive environment or severe operating conditions (24 hours per day), it is recommended that oil be changed every month.

5. If the clutch is out of service or in storage for two years or more, new seals should be installed before putting clutch into service.

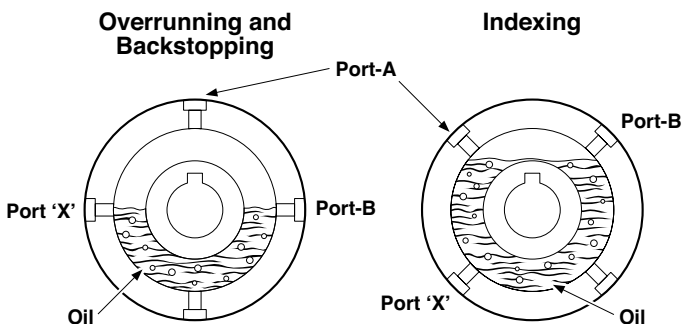

**Note: Models FSO-300 through -600 do not have Port 'X'. Position as shown without Port 'X'**

## Oil Lubrication - Filling Procedure

### Overrunning and Backstopping Applications

1. Rotate the clutch outer race to locate two oil ports at positions (A) and (B) as shown on illustration for Overrunning.
2. Remove (A) and (B) plugs and add oil through (A) until oil flows from (B). The clutch will then be one-half full. Use a pressure can for best results.
3. Install both plugs and tighten to prevent leakage. Plugs on some models consist of a buttonhead screw and leather washer. Be sure the washer is in place.

**Indexing Applications** 0 to 149 strokes per minute (150 strokes per minute or more – use Models HPI, see Bulletin 2213).

1. Rotate the clutch outer race to locate two oil ports at positions (A) and (B) as shown in the illustration for indexing.
2. Remove (A) and (B) plugs and add oil through (A) until oil flows from (B). The clutch will then be 7/8 full. Use a pressure can for best results.
3. Install both plugs and tighten to prevent leakage.

### Flushing Procedure

1. Rotate the clutch outer race to locate one oil port at lowest point of the outer race.
2. Remove lowest plug and drain clutch of oil. Remove the top plug to vent for better drainage.
3. Install bottom drain plug and fill clutch completely full with mineral spirits. Re-install the top plug.
4. Rotate clutch slowly for several minutes to break up and dissolve oily residue which may have formed.
5. Remove lower plug and drain all mineral spirits from the clutch assembly. Remove top plug to vent for better drainage.
6. Replace and tighten the lower plug.
7. Relubricate the clutch according to Oil Lubrication Filling Procedure.
8. Replace top plug, then tighten all plugs to prevent leakage.

## Grease Lubrication

Use greases selected from the following:

Fiske Bros. Lubriplate Low-Temp

Fiske Bros. Aero Lubriplate

Exxon Beacon 325

(-40°F to +150°F/-40°C to +65°C)  
(Maximum permissible ambient temperature)

Shell Aeroshell No. 7

Shell Aeroshell No. 22

Shell Aeroshell No. 16

SFL -1 grease (Food grade)

**Note:** FSO 300 thru 700 are packed at the factory with the Fiske Brothers "Lubriplate Low Temp" and FSO-750 thru FSO-1027 are packed with Fiske Brothers Aero Lubriplate.

- Use no other greases unless a specific recommendation has been made by Formsprag Clutch.
- If operation at ambient temperatures below +20°F/-7°C or above +120°F/ + 55°C is required, consult Formsprag Clutch for special lubricant recommendations.
- Grease lubrication may be used if:
  - The clutch is inaccessible for frequent maintenance.
  - Conditions do not permit the type of maintenance required for oil lubricated clutches.
  - The clutch is mounted on a vertical shaft.
  - The clutch is operated in the presence of severe abrasive dust.
- Do not attempt to substitute grease lubrication in a standard oil lubricated clutch. The use of grease lubrication in a clutch intended for oil could cause a malfunction.
- Formsprag Clutch can convert in-service clutches from oil to grease lubrication. Changes in internal construction are usually required. Consult the Formsprag Service Department, giving complete model number.

## Grease Lubrication Maintenance

Application	Add Grease	Add Grease Under Rugged Conditions*
Overrunning	Every 3 months	Every 2 weeks
Backstopping	Every 3 months	Every 2 weeks
Indexing	Once a month	Every 2 weeks

\*24 hours per day or operation in severe abrasive dust conditions.

## Grease Lubrication Procedure

1. Wipe all grease fittings clean, then pump new grease into all fittings until clean grease flows out completely around the seals on both sides of the clutch.
2. Lubrication should be done with the clutch at normal operating temperature.

## Use Recommended Greases Only

### Packaging

Your Formsprag clutch is carefully wrapped in Vapor Inhibitor type activated paper for corrosion protection and packed in a shipping box conforming to the requirements of Rule 41, Uniform Freight classification, may be stored for up to two (2) years and reshipped without added packaging.

Models 300 through 400 are packed in corrugated board shipping boxes and models 750 through 1027 in wooden, style 4 shipping boxes with integral skids. To store in an unprotected area or if the original packaging is opened, wrap the box with a waterproof covering.

### Clutch Rebuilding Service

**⚠CAUTION** Disassembly and repair of Formsprag clutches in the field is not recommended.

Formsprag clutches are precision devices manufactured under careful controls to meet exacting standards. When reconditioning is required, clutches should be returned to Formsprag Clutch, (Purchase Orders must go directly or through your local Warner Electric Distributor, or through the Original Equipment Manufacturer).

These instructions cannot cover all details or variations in equipment and applications, nor provide for every possible contingency which may be met in installation, operation or maintenance. Should further information be needed, contact Formsprag Clutch.

### Rotating Equipment

Rotating equipment is potentially dangerous and should be properly guarded. The user should check for all applicable safety codes in his area and provide a suitable guard.

For additional technical and dimensional information on FS/FSO clutches refer to Formsprag Overrunning Clutch Catalog P-956-FC or call 800-927-3262.

## Warranty

Formsprag Clutch LLC warrants that it will repair or replace (whichever in its sole discretion it deems advisable) any product it manufactured and sold which proves to be defective in material or workmanship within a period of one (1) year from date of original purchase for consumer, commercial or industrial use. This warranty extends only to the original purchaser and is not transferable or assignable without Formsprag LLC's prior consent.

This warranty covers normal use and does not cover damage or defect which results from alterations, accident, neglect, disassembly, or improper installation, operation, or maintenance.

Formsprag LLC's obligation under this warranty is limited to the repair or replacement of the defective product. In no event shall Formsprag LLC be liable for consequential, indirect or incidental damages of any kind incurred by reason of manufacture, sale or use of any defective product. Formsprag LLC neither assumes nor authorizes any other person to give any other warranty or to assume any other obligation or liability on its behalf.



[www.formsprag.com](http://www.formsprag.com)

23601 Hoover Road  
Warren, MI 48089  
586-758-5000