

Airflex Product Line

PDC 16300 – Installation,
Operation and Maintenance of PDC Assemblies

204268



Table of contents

Section	Description	Page
1.0	Introduction	4-5
1.1	Description	5
1.2	How it works	5
2.0	Installation	6
2.1	Mounting arrangements	7
2.2	Shaft fits -hub and spider	7
2.3	Mounting the PDC – interference fits	7
2.4	Mounting the PDC – alternate methods	8
2.5	Mounting the spider	9
2.6	Shaft-to-shaft mounting arrangement	10
2.7	Clearances and adjustment	10
2.8	Alignment	11
2.9	Air connections	12
3.0	Operation	12
3.1	Pressure, speed and temperature limits	13
3.2	Initial operation	13
3.3	Lubrication	13
4.0	Maintenance	13
4.1	Periodic inspection	13
4.2	Wear limits	13
4.3	Wear adjustment	14
4.4	Friction disc replacement	14
4.5	Air tube replacement	14
4.6	Disassembly	15
4.7	Reassembly	15
5.0	Technical assistance	16
6.0	Part lists	17
6.1	PDC assemblies	17
6.2	PDC spiders	18
7.0	Revisions	19

List of figures

Figure	Description	Page number
1	PDC assembly components	4
2	Shaft to shaft arrangement - standard spider	6
3	Shaft to shaft arrangement - quick change spider	6
4	Operating clearance measurement	10
5	Alignment check setup	12

List of tables

Table	Description	Page number
1	Fastener torque specifications	7
2	Shaft to shaft gaps (X)	10
3	Fasteners lengths - driving ring mounting	10
4	Operating clearances	11
5	Alignment specifications	11
6	Maximum operating speeds	12
7	Component wear limits	13

Airflex PDC Assemblies

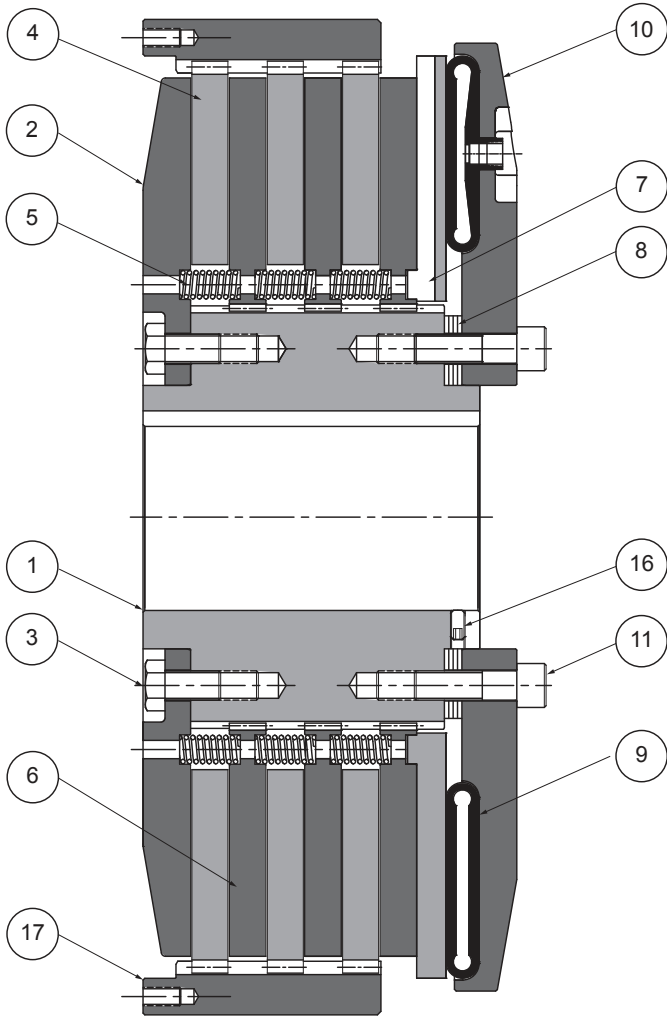

Item	Description
1	Hub
2	Back plate
3	Hex head cap screw
4	Friction disc
5	Release spring
6	Center plate
7	Pressure plate
8	Shim
9	Air tube
10	Tube holding plate
11	Socket head cap screw
16	Set screw
17	Driving ring

Figure 1

Airflex PDC Assemblies

1.0 Introduction

Throughout this manual there are a number of HAZARD WARNINGS that must be read and adhered to in order to prevent possible personal injury and/or damage to equipment. Three signal words "Danger", "Warning", and "Caution" are used to indicate the severity of a hazard, and are preceded by the safety alert symbol. ⚠



Danger

Denotes the most serious hazard, and is used when serious injury or death WILL result from misuse or failure to follow specific instructions.



Warning

Used when serious injury or death MAY result from misuse or failure to follow specific instructions.



Caution

Used when injury or product/equipment damage may result from misuse or failure to follow specific instructions.

It is the responsibility and duty of all personnel involved in the installation, operation and maintenance of the equipment on which this device is used to fully understand the

⚠ Danger, ⚠ Warning, and, ⚠ Caution procedures by which hazards are to be avoided.

1.1 Description

1.1.1 The Airflex Pneumatic Disc Clutch (PDC) is an air actuated, spring release, in-line power transmission clutch best suited for applications requiring large inertia loads and smooth starting. All Airflex PDC units are supplied with long wearing, NON-ASBESTOS friction material. The hub is machined from high strength alloy steel for greater service life.

1.1.2 Airflex PDC assemblies are available in four basic sizes and can be supplied as single, dual or triple disc units. The model number identifies the number of friction discs and the nominal diameter of the back plate. For example, a "224 PDC" indicates a clutch with 2 friction discs and a 24 inch nominal outside diameter of the back plate. When size such as 24PDC is referred to in this manual it means that the information given applies to all PDC models having a 24 inch diameter back plate, i.e. 124PDC, 224PDC, etc..

1.1.3 This manual includes metric equivalents shown in parentheses (#) following the U.S. measurement system value. Be sure to use the correct value.

1.1.4 Product component descriptions listed throughout this manual are followed by item numbers in parentheses, such as hub (1) or back plate (2). Refer to Figure 1 for an illustrated view of the component and its location within the assembly, or to the part list table at the back of the manual for relevant Eaton part numbers.

1.2 How it works

1.2.1 Referring to Figures 1 and 2, the driving ring (17) is typically connected to the prime mover (driving shaft or a flywheel) and the hub (1) is typically connected to the driven shaft. The friction discs (4) are coupled to the driving ring via splines and the center plates (6) are coupled to the hub (1) via splines. The spline connections allow for the friction discs and center plates to slide axially during engagement and release of the PDC.

1.2.2 Air pressure is applied and exhausted through one or more ports in the air tube (9) that is contained between the tube holding plate (10) and the pressure plate (7). As the applied air pressure increases to overcome the force of the release springs (5) the air tube expands, compressing the release springs and moving the pressure plate (7), center plates (6) and friction discs (4) towards the back plate (2), clamping them against one another, connecting the driving and driven shafts.

1.2.3 As air pressure is exhausted, the release springs force the pressure plate and center plates away from the back plate, releasing the clamp force from the friction discs, allowing them to turn freely in respect to the center plates and back plate when air pressure is fully exhausted, disconnecting the driving and driven shafts.

Airflex PDC Assemblies

2.0 Installation



Danger

Prior to installation of the PDC assembly and related adapters, make sure that the machinery is locked out and any hazardous energy is isolated. Failure to do so could result in serious personal injury or possibly death.



Warning

Only qualified personnel should install, adjust or repair these units. Faulty workmanship will result in exposure to hazardous conditions and/or personal injury.

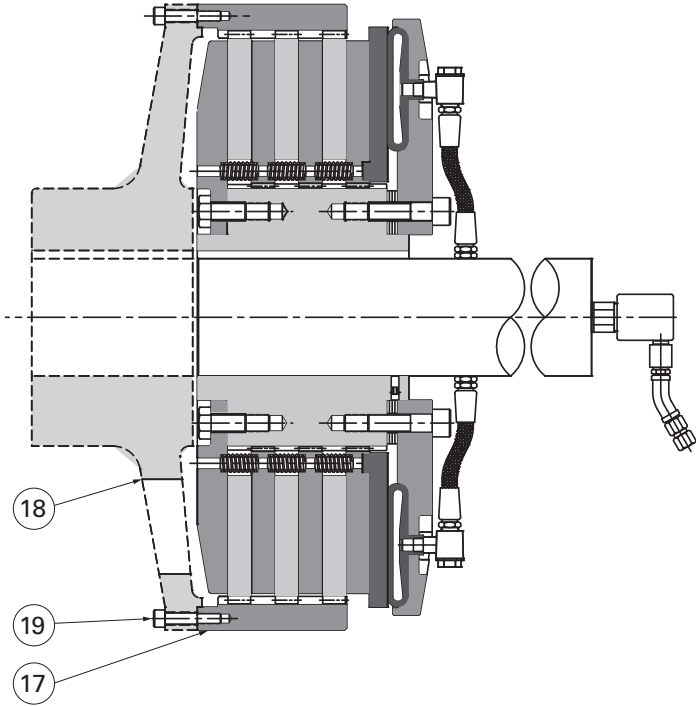

Figure-2 Spider arrangement

Item	Description
17	Driving ring
18	Spider
19	Socket head cap screw

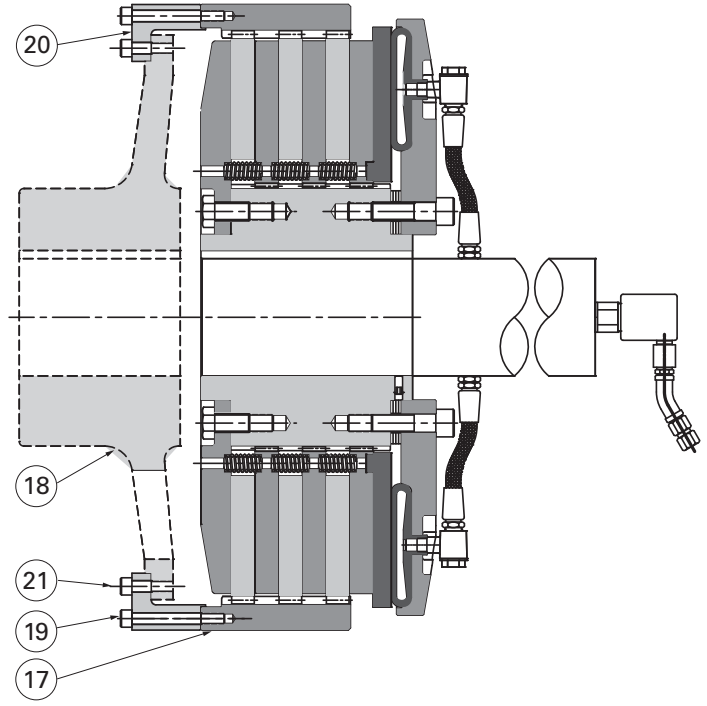

Figure-3 Spider with quick change ring

Item	Description
20	Quick change ring
21	Socket head cap screw

Airflex PDC Assemblies

2.1 Mounting arrangements

- 2.1.1 The PDC assembly can be installed in a variety of drive configurations including close shaft-to-shaft mount with the driving ring (17) attached to spider per Figure 2, use of quick change ring and spider to accommodate in-place friction disc replacement per Figure 3, and various other custom arrangements that support the driving ring. The following instructions provide guidance for the standard arrangements shown in Figures 2 and 3.
- 2.1.2 For all arrangements it is extremely important that shafting is positioned so that the driving ring (17) is fully engaged over the friction discs (4) at all times and that there is no interference or contact between the driving ring and all other PDC components other than the friction discs. Be sure that adjacent support shafts are properly controlled via bearings or other limiters to prevent interference or non-intentional contact between the driving and driven shafts and related components.
- 2.1.3 Positioning and orientation of the PDC should be arranged to provide access for wear adjustment and removal of shims (8). Wear adjustment requires axial clearances to allow for removal and reassembly of socket head cap screws (11) and the tube holding plate (10). The shims are split (two-piece) to accommodate mid-shaft removal.
- 2.1.4 When used as a clutch, a means of connecting the air piping to the PDC element is necessary. Refer to the relevant catalog dimensions for port locations on the PDC assembly.

2.2 Shaft fits - hub and spider

- 2.2.1 Eaton recommends an interference fit between machine shafting and the PDC hub (1) or spider. Alternate methods are possible yet may result in imbalance or looseness of the PDC components on the shafting and subsequent damage to shafting and PDC components.
- 2.2.2 Alternate methods to secure the PDC hub (1) or spider to the shaft include:
- Parallel keys with stepped shaft and retaining end plate
 - A tapered key
 - Key and set screw fitted in the hub



Warning

Only qualified personnel should install, adjust or repair these units. Faulty workmanship will result in

exposure to hazardous conditions and/or personal injury.

2.3 Mounting the PDC – interference fits

- 2.3.1 Mounting the PDC hub onto the shafting with an interference fit can be accomplished by freezing the shaft or heating the hub (1) so that the bore of the hub is clear to slide over the shaft without force. Heating the hub requires the PDC assembly to be fully disassembled and then reassembled after the hub cools.
- 2.3.2 Disassemble the PDC assembly per 4.6 in the Maintenance section. Be sure to match mark the back plate (2) and tube holding plate (10) to the hub (1) prior to disassembly.
- 2.3.3 Clean the hub (1), removing any oil, grease or contamination from the surfaces.
- 2.3.4 Ensure that the shaft is free of nicks or burrs and that the key fits properly in the shaft and hub (1).
- 2.3.5 Position the tube holding plate (10) onto the shaft, noting the orientation for proper reassembly.
- 2.3.6 Rotate the shaft so that the keyway is facing up. Fit the (customer provided) key into the keyway.
- 2.3.7 Apply a very light coat of anti-seize compound onto the shaft, key and in the hub bore and keyway.
- 2.3.8 Heat the hub (1) uniformly to 250° F (121° C). Use of an oven is the preferred method of heating the hub, however if using torches use a broad flame and keep the torch moving to prevent ‘hot-spots’ that can damage the hub.



Warning

Use appropriate personal protection and lifting equipment to prevent burns and injury when handling heated components.

- 2.3.9 Noting the proper orientation of the hub (1), slide the hub onto the shaft and over the key. Typically the end of the hub will be mounted so that it is even with the end of the shaft. Allow the hub to cool to ambient temperature.
- 2.3.10 Aligning match marks made in 2.3.2, assemble the tube holding plate (10) to the hub (1) with socket head cap screws (11) while placing the shims (8) in position. Since the shims are split into semi-circles, be sure to install an equal number of shim halves so that the shims are of equal height when mounted between the hub and tube holding plate.

Airflex PDC Assemblies

Table 1
Fastener torque specifications (Lubed)

	Fastener size	1/4	5/16	3/8	7/16	1/2	5/8	3/4	7/8	1
Torque Lb*ft (N-m)	Socket head cap screw	17 (23)	35 (47)	63 (85)	100 (136)	150 (203)	210 (284)	500 (678)	700 (950)	900 (1220)
	Hex head screw (grade 8)	9 (12)	18 (24)	35 (47)	55 (75)	80 (108)	170 (230)	280 (380)	460 (624)	650 (881)
	Set Screw (Item 16)	-	-	22 (30)	-	50 (67)	-	-	-	-

2.3.11 One at a time, remove a socket head cap screw (11), apply Loctite 242 to the threads of the screw and reassemble the screw into the hub. Tighten the screw to the proper torque value listed in Table 1. Repeat for the remaining socket head cap screws.

2.3.12 Place the air tube (12) in position against the tube holding plate (10) so that the metal valves in the air tube align with the corresponding holes in the tube holding plate.

2.3.13 Aligning match marks made in 2.3.2, re-assemble the pressure plate (7), center plates (6), release springs (5) and friction discs (4) into their original positions. Use dowels or rods through the center of the release springs to temporarily hold the springs in position.

2.3.14 Rig the back plate (2) into position, align match marks and assemble onto the hub (1) with hex head screws (3). Tighten the hex head screws gradually to evenly draw the back plate into position against the hub until the screws are snug.

2.3.15 Remove the rods or dowels inserted in 2.3.13

2.3.16 One at a time, remove a hex head screw (3), apply Loctite 242 to the screw threads and reassemble the screw. Tighten the screw to the proper torque value listed in Table 1. Repeat for the remaining screws.

2.3.17 After assembly, proceed to 2.5 through 2.9 for final installation.

2.4 Mounting the PDC – alternate methods

2.4.1 Hydraulic actuation system

2.4.1.1 Ensure that the shaft is free of nicks or burrs and that the key fits properly in the shaft and hub (1).

2.4.1.2 Fit and secure the (customer provided) keys into the keyways.

2.4.1.3 Apply a very light coat of anti-seize compound onto the shaft, keys and in the hub bore and keyway.

2.4.1.4 Noting the proper orientation of the keyways, rig the PDC assembly into position and slide it onto the shaft and over the keys until it bottoms against the shoulder on the shaft.

2.4.1.5 Secure the PDC hub onto the shaft with the customer provided retaining plate and associated fasteners. It is recommended that any gap between the retaining plate and end of the shaft be filled with a shim to prevent deflection of the plate. Tighten the fasteners to the appropriate torque values, securing them with Loctite or lockwires to help prevent loosening during operation.

2.4.1.6 Align the splines on the friction discs (4) and carefully slide the driving ring (17) over the friction discs, noting the orientation of the mounting holes on the driving ring. Do not lubricate the splines of the friction discs or driving ring.

2.4.1.7 Proceed to 2.5 through 2.9 for final installation.

2.4.2 Tapered key mounting

2.4.2.1 Ensure that the shaft is free of nicks or burrs and that the key fits properly in the shaft and hub (1).

2.4.2.2 Apply a very light coat of anti-seize compound onto the shaft and in the hub bore.

2.4.2.3 Noting the proper orientation of the keyway, rig the PDC assembly into position and slide it onto the shaft, aligning the keyways.

2.4.2.4 Tap the tapered key into the keyway until secure.

Airflex PDC Assemblies

2.4.2.5 Align the splines on the friction discs (4) and carefully slide the driving ring (17) over the friction discs, noting the orientation of the mounting holes on the driving ring. Do not lubricate the splines of the friction discs or driving ring.

2.4.2.6 Proceed to 2.5 through 2.9 for final installation.

2.4.3 Key and set screw

2.4.3.1 Ensure that the shaft is free of nicks or burrs and that the key fits properly in the shaft and hub (1).

2.4.3.2 Rotate the shaft so that the keyway is facing up. Fit the (customer provided) key into the keyway.

2.4.3.3 Apply a very light coat of anti-seize compound onto the shaft, keys and in the hub bore and keyway.

2.4.3.4 Noting the proper orientation of the keyway, rig the PDC assembly into position and slide it onto the shaft, aligning the keyways.

2.4.3.5 Match mark the tube holding plate (10) to the hub (1).

2.4.3.6 Use dowels or rods inserted through the holes in the back plate (2) to help keep the release springs (5) in position during assembly and reassembly.

2.4.3.7 Loosen the socket head cap screws (11) from the PDC assembly. Slide the tube holding plate (10), air tube (9), socket head cap screws (11), shims (8) and pressure plate (7) along the shaft to gain access to the set screw hole and set screw (16) in the PDC hub (1).

2.4.3.8 Tighten the set screw (16) in the hub to the torque value listed in Table 1.

2.4.3.9 Reassemble the pressure plate (7) onto the hub (1), aligning the bosses near the inner diameter of the pressure plate with the counterbores of the adjacent center plate (6). Reposition the pressure plate as needed so that there is no gap between the pressure plate and center plate.

2.4.3.10 Using the socket head cap screws (11) to hold the shims (8) in position against the tube holding plate (10), rig the tube holding plate, air tube (9) and shims (8) into position on the hub (1), aligning the match marks made prior to disassembly. Draw the tube holding plate onto the hub by evenly tightening the socket head cap screws until snug.

2.4.3.11 Remove the dowels or rods inserted in 2.4.3.6 that temporarily held the release springs in position.

2.4.3.12 Verify that the clearances are within the acceptable range as listed in Table 4 by following the procedures in the adjustment section. Adjust per 2.7 if necessary.

2.4.3.13 One at a time, remove a socket head cap screw (11), apply Loctite 242 to the threads of the screw and re-assemble the screw into the hub. Tighten the screw to the proper torque value listed in Table 1. Repeat for the remaining socket head cap screws.

2.4.3.14 Proceed to 2.5 through 2.9 for final installation.

2.5 Mounting the spider

2.5.1 The spider should be bored to provide an interference fit on the shaft.

2.5.2 Ensure that the shaft is free of nicks or burrs and that the key fits properly in the shaft and spider.

2.5.3 Rotate the shaft so that the keyway is facing up. Fit the (customer provided) key into the shaft keyway.

2.5.4 Apply a very light coat of anti-seize compound onto the shaft, key and in the bore and keyway in the spider.

2.5.5 If a spider and quick change ring is being used as shown in Figure 3, rig the quick change ring over the shaft prior to assembling the spider onto the shaft. Note the orientation of the flange on the quick change ring so ensure that it is positioned correctly.

2.5.6 Heat the spider uniformly to 250°F (121°C). Use of an oven is the preferred method of heating however if using torches, use a broad flame and keep the torch moving to prevent 'hot-spots' that can damage the spider.



Warning

Use appropriate personal protection and lifting equipment to prevent burns and injury when handling heated components.

2.5.7 Noting the proper orientation of the spider and keyway, slide the spider onto the shaft and over the key. Typically the face of the hub area of the spider will be mounted so that it is flush with the end of the shaft. Allow the spider to cool to ambient temperature.

Airflex PDC Assemblies

2.6 Shaft-to-shaft mounting arrangement

- 2.6.1 Mount the PDC assembly and spider per the appropriate procedures listed in 3.3 through 2.5. Ensure that the driving ring (17) is assembled over the friction discs (4) and oriented correctly so that it can be assembled to the spider.
- 2.6.2 Position the machinery to establish the appropriate gap between the spider and the face of the back plate (2). See Figures 2, 3 and Table 2.

Table 2
Shaft to shaft gaps (X), inches (mm)

Size	With standard spider	With quick change adapter
18 PDC	0.75 (19.1)	2.13 (54.1)
24 PDC	0.75 (19.1)	3.38 (85.9)
27 PDC	0.75 (19.1)	2.44 (62.0)
30 PDC	0.75 (19.1)	3.50 (88.9)

Note: Tolerance on all values is +/- 0.063 (1,60)

- 2.6.3 While maintaining the axial position established in 2.6.2, shim and shift the equipment to allow for assembly of the driving ring to the spider or quick change ring.
- 2.6.4 If a quick change ring (20) is used, attach it to the spider using socket head cap screws (21). Referring to Table 1, tighten the socket head cap screws to the proper torque value.
- 2.6.5 Assemble the driving ring to the spider (17) or quick change ring using the appropriate length and type of fasteners as listed in Table 3. Tighten the screws to the torque value listed in Table 1.

Note: For mounting the driving ring to the spider, use socket head cap screws conforming to ASTM A574.

Table 3
Fastener lengths to mount driving ring

Size	Spider to driving ring	Spider to quick change ring	Quick change ring to driving ring
18 PDC	1.75"	1.50"	4.50"
24 PDC	2.00"	1.75"	2.25"
27 PDC	2.00"	2.00"	3.00"
30 PDC	2.00"	2.25"	3.00"

Note: All fasteners are 5/8-11 NC-3 socket head cap screws

- 2.6.6 Align the shafts per the procedures and alignment specifications listed in 2.8. Ensure that the shaft to shaft gap as listed in Table 2 has been maintained after final alignment has been achieved.
 - 2.6.7 Assemble air connection fittings and hoses as appropriate for the desired arrangement, using good quality pipe sealant on all pipe thread connections. The port size is 1/2" NPT in all air tubes (9). If quick release valves or elbow fittings are being used to connect the ports in the air tube with the ports in the shafting, orient the fittings or valves to allow for a roughly 90° bend in the hose connection to accommodate hose installation.
 - 2.6.8 Install the rotorseal into the end of the shaft and connect the air supply with a "loop" of flexible hose to reduce force on the rotorseal.
 - 2.6.9 Verify that clearances are within specification per the procedures in 2.7 and adjust if required prior to placing the PDC into service.
- ## 2.7 Clearances and adjustment
- 2.7.1 Check friction disc running clearances using Table 4. Shims (8) are used to set proper clearances and to compensate for disc wear. Apply and release air pressure while measuring axial movement of the pressure plate (7). Refer to Figure 4.
 - 2.7.2 Add or remove shims (3) to achieve a value within the range listed in Table 4 per the following procedures:
 - 2.7.3 Match mark the air tube holding plate (10) to the hub (1).

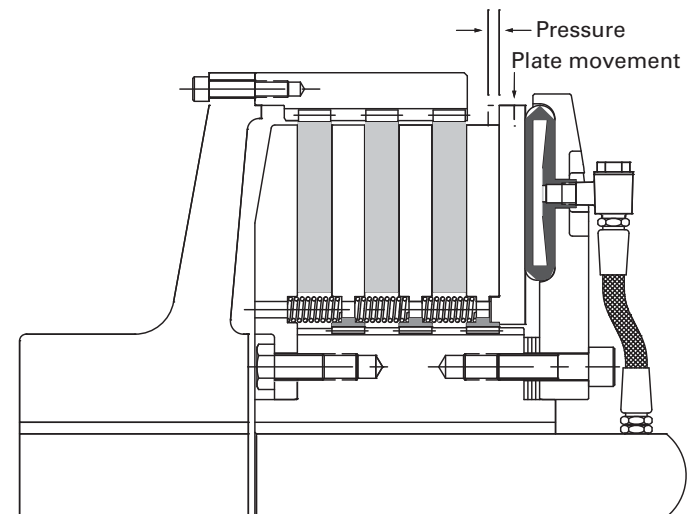

Figure-4

Airflex PDC Assemblies

Table 4
Operating Clearances

PDC size	Minimum operating clearances, inches (mm)			Maximum clearance
	One disc	Two discs	Three discs	
18	1/16 - 3/32 (1.5-2.3)	3/32 - 1/8 (2.3-3.0)	1/8 - 3/16 (3.0-4.5)	1/2 (12.7)
24 and 27	3/32 - 1/8 (2.3-3.0)	1/8 - 5/32 (3.0-3.8)	5/32 - 3/16 (3.8-4.5)"	1/2 (12.7)
30	3/32 - 1/8 (2.3-3.0)	1/8 - 5/32 (3.0-3.8)	3/16 - 1/4 (4.5-6.3)"	5/8 (15.7)

- 2.7.4 Use dowels or rods inserted through the holes in the back plate (2) to help keep the release springs (5) in position during assembly and reassembly.
- 2.7.5 Loosen the socket head cap screws (11) from the PDC assembly. Slide the tube holding plate (10), air tube (9), socket head cap screws (11), shims (8) and pressure plate (7) along the shaft to gain access to the set screw hole and set screw (16) in the PDC hub (1).
- 2.7.6 Tighten the set screw (16) in the hub to the torque value listed in Table 1.
- 2.7.7 Reassemble the pressure plate (7) onto the hub, aligning the bosses near the inner diameter of the pressure plate with the counterbores of the adjacent center plate (6). Reposition the pressure plate as needed so that there is no gap between the faces of the pressure plate and center plate.
- 2.7.8 Using the socket head cap screws (11) to hold the shims (8) in position against the tube holding plate (10), rig the tube holding plate, air tube (9) and shims (8) into position on the hub (1), aligning the match marks made prior to disassembly. Draw the tube holding plate onto the hub by evenly tightening the socket head cap screws until snug.
- 2.7.9 Remove the dowels or rods inserted in 2.7.4 that temporarily held the springs in position.
- 2.7.10 One at a time, remove a socket head cap screw (11), apply Loctite 242 to the threads of the screw and re-assemble the screw into the hub. Tighten the screw to the proper torque value listed in Table 1. Repeat for the remaining socket head cap screws.

2.8 Alignment

- 2.8.1 When mounting shaft-to-shaft as shown in Figures 2 and 3, the axial position between shafts must be maintained to ensure proper engagement of the driving ring (17) over the friction discs (4) and so that the opposing shafts - or PDC components mounted on opposing shafts - do not make inadvertent contact with one another.



Warning

Failure to ensure proper clearances between driving and driven shafts and related clutch components may result in unexpected movement of machinery and subsequent personal injury or damage to adjacent components.

- 2.8.2 Check both parallel and angular alignment using a dial indicator as shown in Figure 5. Rotate each configuration 360° and record total indicator reading (TIR) which is the difference between the maximum and minimum values observed on the dial indicator. Compare with maximum values in Table 5 and adjust machinery to bring the shaft positions within the allowable limits.

Note: Alignment checks using this method require that both the driving and driven shafts be rotated or indexed together to avoid the influence of runout that may exist on components. If this is not possible, rotate and record runout values on the driving ring (17) and use the runout values to calculate and correct the indicator readings when rotating only one shaft.

Table 5
Alignment specifications

Size	Parallel (A)		Angular (B)	
	in	mm	in	mm
18 PDC	0.009	0.23	0.009	0.23
24 PDC	0.012	0.30	0.012	0.30
27 PDC	0.014	0.36	0.014	0.36
30 PDC	0.015	0.38	0.015	0.38

- 2.8.3 Thermal growth of machinery and bearing clearances can have an adverse effect on alignment readings. Always be sure to compensate for these influences to ensure that shaft alignment is within the acceptable limits listed in Tables 3 and 5. Verification of alignment with machinery at operating temperatures is recommended.

Airflex PDC Assemblies

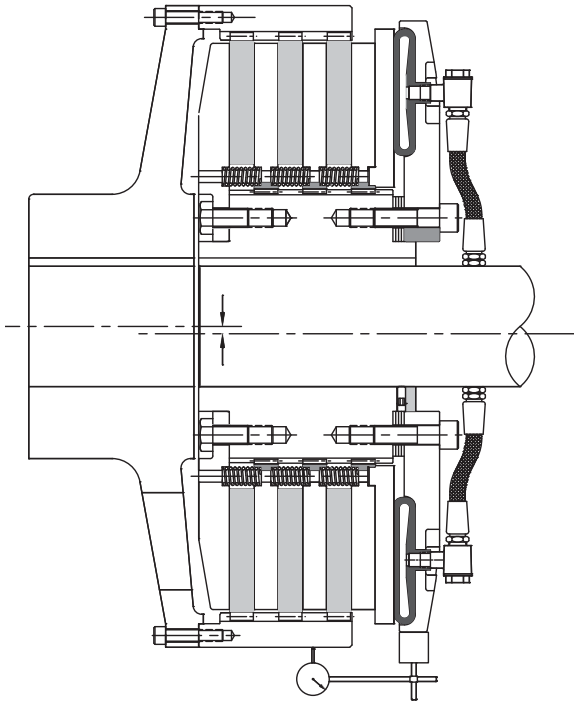

Figure-5 A. Parallel alignment

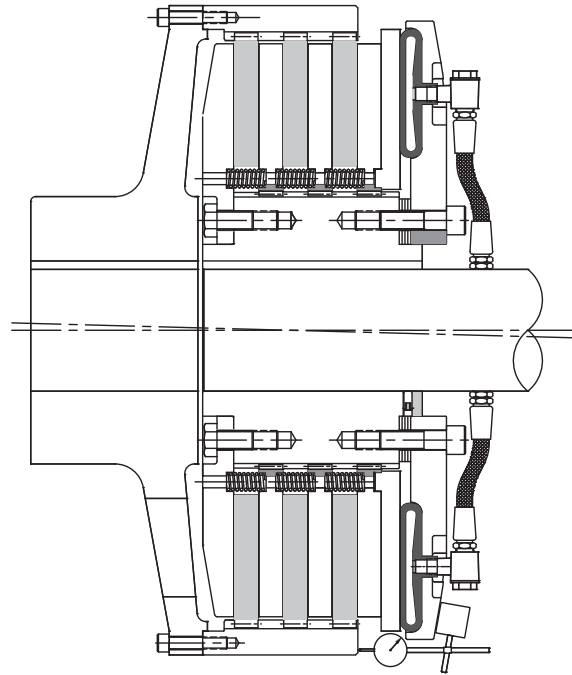

Figure-5 B. Angular alignment

2.9 Air connections

- 2.9.1 The port size in the air tube (9) for all PDC sizes is ½" NPT. Be sure to use the appropriate air connection fittings to prevent damage and to help ensure a good seal. Use of a liquid thread sealing compound on the threads is recommended.
- 2.9.2 The use of flexible hoses between the shaft and ports on the PDC air tube (9) is recommended to accommodate repositioning of the tube holding plate (10) when shim adjustments are made. Be sure that hoses are of adequate length to accommodate this adjustment.
- 2.9.3 Quick Release valves (QRV's) can also be installed between the flexible hoses and the air tube ports to accommodate faster exhaust of the air pressure and release of the clutch. Contact your local Airflex distributor for assistance in identifying appropriate QRV's for use with your application.

3.0 Operation

3.1 Pressure, speed and temperature limits

- 3.1.1 Maximum allowable applied pressure is 100 psi (8,2 bar).



Warning

Operation at pressures exceeding maximum allowable may result in damage to the PDC components.

- 3.1.2 Maximum allowable operating speeds are shown in Table 6.



Warning

Operation at speeds exceeding the maximum allowable as listed in Table 6 may result in personal injury or product / equipment damage.

- 3.1.3 Operating temperature limits for the PDC are -4° F (-20° C) to +158° F (70° C).

Table 6
Maximum operating speed

Size	Maximum operating speed, RPM
18 PDC	1750
24 PDC	1350
27 PDC	1200
30 PDC	1100

Airflex PDC Assemblies

3.2 Initial operation

3.2.1 After clearance and alignment checks have been completed, insure that all air connections have been made and are tight. Engage and disengage the clutch and confirm that the release springs (5) are pushing the pressure plate (7) back to the original position. Watch for any unusual vibrations or noise during operation. Correct any issues noted prior to continued operation.

3.2.2 The non-asbestos friction material used in PDC assemblies may not develop rated torque initially as a short wear-in period is required. Monitor the operation of the PDC initially and limit loads to avoid excessive slipping until the friction interface is fully worn in.

3.3 Lubrication

3.3.1 The PDC does not require periodic lubrication other than initial lubrication of the splines on the hub (1) during assembly.

4.0 Maintenance



Warning

Prior to performing maintenance on the PDC, make sure that the equipment is in, and will remain in a safe condition.

4.1 Periodic inspection

4.1.1 Watch for unusual noises or vibrations that may indicate excessive wear or damage to components. Investigate for wear, referring to the limits listed in Table 7 and Section 2.7 for guidance.

4.1.2 Periodically check for air leaks in air piping or the air tube (7) and repair or replace components as needed.

4.1.3 As the friction material wears, adjustment may be required to keep the clearances and allowable expansion of the air tube within an acceptable range. See Section 2.7 for procedures to check clearances and make adjustments.

4.2 Wear limits

4.2.1 Wear limits for the PDC components are shown in Table 7. If any wear limit has been reached or exceeded, that component must be repaired or replaced. Be sure to inspect mating components when replacing components such as friction discs (4), as it is often found that mating components should be replaced at the same time.



Warning

If wear adjustment is not made or worn part replaced when limits have been reached, product failure or machinery malfunction could occur.

Table 7

Wear limits

Item	Component	Description	Wear limit		Remarks
1	Hub	Spline wear	TBD		
2	Back plate	Friction wear surface	Maximum wear is 0.031" (0.80mm)		Surface should be machined flat (not to exceed max wear allowance) or component replaced when replacing friction discs.
6	Center plate				
7	Pressure plate				
4	Friction disc	Minimum thickness	New	Minimum	Check wear surface of back plate (2), center plate (6) and pressure plate (7) if replacing friction discs
			18PDC: 0.62 (15,9)	0.44 (11,2)	
			24/27PDC: 0.88 (22,4)	0.63 (16,0)	
			30PDC: 1.25 (31,7)	0.94 (23,9)	
4	Friction disc	Spline wear	TBD		
6	Center plate	Spline wear	TBD		
9	Air tube	Material condition	Leaks, blisters, cracks or hardening of material		Max hardness allowable is 72 durometer, shore A scale.
17	Driving ring	Spline wear	TBD		

Airflex PDC Assemblies

4.3 Wear adjustment

- 4.3.1 As the friction discs wear, adjustment may be required to keep the clearances and allowable expansion of the air tube (9) within an acceptable range. See section 2.7 for procedures to check clearances and make adjustments. If all shims (9) have been removed and the wear limit has been reached, replace the friction discs per 4.4.

4.4 Friction disc replacement



Caution

Use only Airflex supplied friction discs. Use of non-Airflex components may void warranty and result in diminished performance and premature iron wear.

Note: After any maintenance, check alignment per section 2.8 and recheck clearances per 2.7.

- 4.4.1 For in-place installation and removal, friction discs (4) can be saw cut into halves to ease installation and removal. Be sure to keep discs in matched sets, marking them to ensure proper assembly and orientation.



Caution

Use appropriate dust collection equipment and other personal protective equipment when sawing or cutting friction material

- 4.4.2 Friction discs (4) should be replaced when the maximum wear limits in Tables 4 and 7 have been reached and adjustment is no longer possible with shims (8). Mating metal surfaces on the center plate (6) and the back plate (2) should be checked for wear and flatness. Re-surfacing is permissible as long as the wear limits have not been reached after machining.



Caution

Failure to verify and correct flatness of wear surfaces of the back plate (2) and center plates (6) when replacing friction discs could result in poor contact of the friction discs and subsequent reduction in torque or erratic performance

- 4.4.3 The driving ring (17) must be moved to replace any friction discs.

Note: Friction discs that were installed in halves may fall out when the driving ring (17) is moved. Use care to support the friction discs when the driving ring is moved.

- 4.4.4 If a quick change ring (20) is being used, remove socket head cap screws (21) and slide the driving ring and adapter ring over the spider (15) to access the friction discs (4). Proceed to 4.4.6.

- 4.4.5 If a quick change ring (20) is not present, the shafting that the spider is mounted on will need to be moved or the spider (15) will need to be released from the shaft. Disassemble the driving ring (17) from the spider and then then move the spider or shafting to allow for removal of the driving ring. Carefully remove the driving ring.

- 4.4.6 Friction discs (4) that were installed in halves can now be removed. Solid discs can be broken or split to remove.



Caution

Use appropriate dust collection equipment and other personal protective equipment when breaking, sawing or cutting friction material.

- 4.4.7 Install new friction discs, ensuring that the grooves in the friction discs are all facing in the same direction.

- 4.4.8 For applications using the quick change ring, slide the driving ring (17) over the new friction discs (4) and assemble the quick change ring (20) to the spider. Tighten the fasteners to the appropriate torque value listed in Table 1. Verify clearances per 2.7 and adjust shims if necessary.

- 4.4.9 For applications using the standard spider, slide the driving ring (17) over the friction discs (4), noting the orientation of the mounting holes. Proceed with alignment and assembly per 2.6 through 2.9.

4.5 Air tube replacement

- 4.5.1 Disconnect air hoses and fittings from the ports on the air tube.
- 4.5.2 Disassemble the driving ring (17) from the spider and move the shafting with spider out of the way.
- 4.5.3 Slide the driving ring (17) off of the friction discs (4), using care to capture the discs if they are split (2 piece). If reusing the friction discs, mark them to assist with reassembly in the same positions and orientation from which they were removed.
- 4.5.4 Match mark the center plates (6) and pressure plate (7) to the tube holding plate (10) to assist with reassembly.
- 4.5.5 Place dowels or rods in the holes in the back plate so help retain the release springs during disassembly.
- 4.5.6 Secure rigging to the back plate (2). Loosen and remove the hex head cap screws (3) that secure the back plate to the hub (1). Remove the back plate.
- 4.5.7 Remove the friction discs (4), center plates (6), release springs (5) and pressure plate (7).

Airflex PDC Assemblies

- 4.5.8 Remove the air tube (9) and discard. Clean the surface of the tube holding plate (10) and place the new air tube into position, aligning the tube valves with the holes in the tube holding plate.
- 4.5.9 Aligning match marks made in 4.5.4, re-assemble the pressure plate (7), center plates (6), release springs (5) and friction discs (4) into their original positions. Use dowels or rods to temporarily hold the springs in position.
- 4.5.10 Rig the back plate (2) into position and assemble onto the hub with hex head screws (3). Tighten the hex head screws gradually to evenly draw the back plate into position against the hub (1) until the screws are snug.
- 4.5.11 Remove the rods or dowels inserted in 4.5.9.
- 4.5.12 One at a time, remove a hex head screw (3), apply Loctite 242 to the screw threads and reassemble the screw. Tighten the screw to the proper torque value listed in Table 1. Repeat for the remaining screws.
- 4.5.13 Proceed with assembly and alignment per 2.6 through 2.9.

4.6 Disassembly

- 4.6.1 Position the PDC assembly on a clean, level surface with the tube holding plate (10) facing up.
- 4.6.2 Loosen the socket head cap screws (11) approximately one turn each and then continue to loosen them evenly (approximately one turn at a time) to prevent the tube holding plate from cocking or binding on the hub (1) until all spring force is relieved. After all spring force is relieved the socket head cap screws may be completely removed. Remove the tube holding plate.



Warning

The tube holding plate is under spring force. Loosen the screws evenly and make sure that the tube holding plate is not binding during disassembly to prevent sudden release of spring forces that may cause injury.

- 4.6.3 Position the PDC assembly on a clean, level surface with the tube holding plate (10) facing up.
- 4.6.4 Remove a center plate (6), friction disc (4) and a set of release springs (5). For multiple disc assemblies, repeat this step until all components have been removed.
- 4.6.5 Using appropriate lifting equipment, reposition the hub and back plate subassembly so that the back plate (2) is facing up.

- 4.6.6 Loosen and remove the hex head cap screws (3). Remove the back plate (2) from the hub (1).
- 4.6.7 Inspect all components for wear or damage using the wear limits in Table 7 as a guide.

4.7 Reassembly

- 4.7.1 Working on a clean flat surface, orient the hub (1) so that the ventilation slots are facing down. Note: the end of the bore having the hole that accommodates the set-screw should be nearest to the work surface.
- 4.7.2 Rig the back plate (2) into position onto the end of the hub (1) and assemble it to the hub with hex head cap screws (3). Apply Loctite 242 to the threads of the screws and tighten to the appropriate torque value as listed in Table 1.
- 4.7.3 Reposition the hub and back plate subassembly so that the back plate (2) is facing down against the work surface.
- 4.7.4 Apply a very light coat of grease (Castrol Molub-Alloy 936SF Super Heavy or equivalent) to the splines on the hub (1).



Caution

Excessive grease applied to hub splines will contaminate the friction interface and effect torque and performance of the PDC assembly.

- 4.7.5 Assemble the set-screw (16) into the threaded hole in the hub (1). Be sure that the ends of the set screw do not extend into the hub bore or beyond the OD of the hub where the shims will be positioned. See Figure 1.
- 4.7.6 Position a friction disc (4) against the back plate (2).
- 4.7.7 Insert the ends of the release springs (5) into the counterbores in the back plate (2) - or center plate (6) if applicable.

Note: A total of six release springs are assembled in each layer.

Note: Use of a .50" (12mm) wood or steel rod can be used to help position and align the release springs. Use a .60" (15mm) diameter rod for size 30PDC.

- 4.7.8 Position a center plate (6) over the springs so that the counterbores align with the ends of the springs and lower it over the hub splines. Be sure that the springs are not cocked and are properly aligned with the counterbores.

Airflex PDC Assemblies

- 4.7.9 For multiple disc assemblies, repeat steps 4.7.6 through 4.7.8 until all friction discs (4), release springs (5) and center plates (6) have been assembled. After assembly of the final center plate, remove the wood or steel rods from the springs if inserted in 4.7.7.
- 4.7.10 Hoist the pressure plate (7) into position and align the bosses on the pressure plate with the counterbores in the center plate (6). Lower the pressure plate onto the center plate, ensuring that the bosses are fully engaged in the counterbores.
- 4.7.11 Install the required number of shims (8) onto the hub (1), aligning the holes with those in the hub. The shims are split into semi circles to accommodate later removal. Be sure to install an equal number of shim halves (semi-circles) so that the shims are of equal height around the hub.
- 4.7.12 Position the air tube (9) onto the face of the pressure plate (7) with the metal valves facing up.
- 4.7.13 Rig the tube holding plate (10) into position and lower the tube holding plate onto the air tube (9). Reposition the air tube as necessary to align the valves in the air tube with the corresponding holes in the tube holding plate.
- 4.7.14 Align the screw holes in the tube holding plate (10) with those in the hub (1) and assemble the tube holding plate to the hub with socket head cap screws (11). Tighten the socket head cap screws to the appropriate torque value listed in Table 1. Do not apply Loctite to the threads of the screws at this time.
- 4.7.15 Plug all but one of the ports in the air tube (9) using ½" NPT pipe plugs. Connect an appropriate regulated air supply to the remaining port and apply air pressure (maximum 100 PSI (7 bar)) to the assembly. Verify that the pressure plate moves within the expected

range as listed in Table 4. Add or remove shims (8) as necessary to assure initial running clearances. Remove the temporary air supply and pipe plugs for the air tube ports.



Warning

Failure to tighten the socket head cap screws to the proper torque value listed in Table 1 prior to applying air pressure in the air tube may result in damage to or potential failure of the PDC components. Do not pressurize the PDC assembly unless all fasteners are tightened to the proper torque value.

- 4.7.16 After clearances have been verified, one at a time, remove each the socket head cap screws (11), apply Loctite 242 to the screw threads, reassemble the screw and tighten to the appropriate torque value listed in Table 1.
- 4.7.17 Adjust the splines of the friction discs (4) so that all are aligned with those on the adjacent friction discs. Using appropriate lifting equipment, hoist and position the PDC assembly over the driving ring (17), align the friction discs splines with those in the driving ring and lower the PDC assembly into the driving ring. Use care to prevent damage to the friction disc splines.

5.0 Technical assistance

- 5.5.1 In any correspondence regarding Eaton / Airflex equipment, refer to the information on the product nameplate and call or write:

Eaton
Hydraulics Group U.S.A.
Airflex Products
9919 Clinton Rd.
Cleveland, Ohio 44144
Tel: (216) 281-2211
Fax: (216) 281-3890
www.eaton.com/hydraulics

Airflex PDC Assemblies

6.0 Part lists

6.1 PDC assemblies

Item	Description PDC assembly*	118 PDC		218 PDC		318 PDC		124 PDC		224 PDC	
		Part number	QTY	Part number	QTY	Part number	QTY	Part number	QTY	Part number	QTY
		146597A		146598A		146599A		146600A		146601A	
1	Hub * (a)	515908-####	1	515909-####	1	515910-####	1	515911-####	1	515912-####	1
2	Back plate	515871	1	515871	1	515871	1	515880	1	515880	1
3	Hex head cap screw	000197X0610	6	000197X0610	6	000197X0610	6	000197X0912	6	000197X0912	6
4	Friction disc	515872	1	515872	2	515872	3	515881	1	515881	2
5	Release spring	417504-02	6	417504-02	12	417504-02	18	417504-01	6	417504-01	12
6	Center plate	515874	1	515874	2	515874	3	515883	1	515883	2
7	Pressure plate	515875	1	515875	1	515875	1	515884	1	515884	1
8	Shim	417524	1	417524	4	417524	8	417525	1	417525	4
9	Air tube	515876	1	515876	1	515876	1	515885	1	515885	1
10	Tube holding plate	515878	1	515878	1	515878	1	515887	1	515887	1
11	Socket head cap screw	000030X0613	6	000030X0613	6	000030X0613	6	000030X0917	6	000030X0917	6
16	Set screw	000369X0205	1	000369X0205	1	000369X0205	1	000369X0205	1	000369X0205	1
17	Driving ring * (b)	515860	1	515861	1	515862	1	515863	1	515864	1

Item	Description PDC assembly*	324 PDC		327 PDC		230 PDC		330 PDC	
		Part number	QTY	Part number	QTY	Part number	QTY	Part number	QTY
		146602A		146604A		146605A		146606A	
1	Hub * (a)	515913-####	1	515915-####	1	515916-####	1	515917-####	1
2	Back plate	515880	1	515889	1	515898	1	515898	1
3	Hex head cap screw	000197X0912	6	000197X0912	8	000197X0913	6	000197X0913	6
4	Friction disc	515881	3	515890	3	515899	2	515899	3
5	Release spring	417504-01	18	417504-01	18	417504-03	12	417504-03	18
6	Center plate	515883	3	515892	3	515901	2	515901	3
7	Pressure plate	515884	1	515893	1	515902	1	515902	1
8	Shim	417525	8	417526	8	417527	4	417527	8
9	Air tube	515885	1	515885	1	515903	1	515903	1
10	Tube holding plate	515887	1	515896	1	515905	1	515905	1
11	Socket head cap screw	000030X0917	6	000030X0917	8	000030X0918	6	000030X0918	6
16	Set screw	000369X0205	1	000369X0407	1	000369X0407	1	000369X0407	1
17	Driving ring * (b)	515865	1	515867	1	515868	1	515869	1

*Note: (a) Specify bore and keyway sizes when ordering.

(b) Driving Ring (17) is not included in the assembly part number. Order Separately.

Airflex PDC Assemblies

6.2 PDC spiders

Description	18PDC	24PDC	27PDC	30PDC
Standard spider *	515989	515991	515993	515995
Quick change spider assembly	515996	515997	515998	515999
Quick change spider *	516001	516003	516005	516007
Quick change ring	516008	516009	516010	516011

***Note:** Basic part numbers shown. Specify bore and keyway sizes when ordering.

Eaton
Hydraulics Group USA
Airflex Division
9919 Clinton Road
Cleveland, OH 44144-1077
Tel: 216-281-2211
Fax: 216-281-3890

Eaton
Hydraulics Group Asia Pacific
Airflex Division
281 Fa Sai Road
Waigaoqiao Free Trade Zone
Shanghai 200131
China
Tel: (+8621) 5048-4811
Fax: (+8621) 5048-4911